



LITE G3 CHUCK QUICK START INSTRUCTION MANUAL

Thank you for purchasing the NOVA LITE G3 Chuck – our new addition to our NOVA woodturning chuck range with advanced features to enhance your chuck performance. It provides a versatile and easy method for fast and secure work holding for all face turning – bowls, egg cups, vases, boxes, goblets and an endless variety of similar projects.

YOUR SAFETY

Keep these instructions in a safe place for future reference.

WARNING: This chuck is capable of contributing to serious injury (as with any other power tool accessory) if this manual guidance is not followed or if it is used improperly on the lathe. Read and understand the lathe owner's manual. If you do not have a manual, contact the supplier of your lathe to obtain one before using the lathe and chuck. User must be professionally trained to use this chuck. Vocational school courses or other expert tuition is recommended.

As with other work holding methods, an extremely cautious and sensible approach is necessary. With the LITE G3 Chuck it is not possible to give exact directions as to the amount of tightening pressure required for adequate work holding or approved chisel cutting techniques. Follow closely strict guidelines in this manual for different jaw types on wood blank diameters and length, plus strictly follow recommended lathe speeds.

Safe Operation:

Eye Protection: Woodturning operations can result in objects being thrown into your eyes which can result in severe eye damage. Protective eye wear must be used at all times. Everyday vision wear is not protective eye wear. We recommend a full-face shield. Always wear eye protection which complies with current ANSI Standard Z87 (USA).

Noise Protection: Use ear plugs or ear defenders. Particularly if the noise exceeds 85dB. Exposure to high levels of noise can lead to hearing problems.

Dust Protection: Use respiratory protective equipment (dust mask, portable respirator device). Exposure to high levels of irritating dust when turning or sanding hardwoods, soft woods and manufactured composite boards (MDF) can result in serious health problems. In addition, adequate workshop dust extraction must be used.

Chuck is properly secured on lathe spindle: Follow mounting instructions for your lathe for faceplates and other spindle fixtures. Do not rotate chuck under power unless workpiece is firmly clamped.

WARNING: LATHE SPEED: Excessive speed is a serious lathe hazard. Always turn at the slowest speed possible. Ideal speed will vary with wood blank size. The larger the blank the slower the speed. Consult your lathe manual or lathe information plate for speed guidelines. Do not attempt to use the chuck unless the recommended lathe speeds to size of wood blank are known. In addition, you must strictly follow the maximum speed limits set out in the operating section of this manual. Do not exceed them under any circumstances.

CHECK WORKPIECE: Examine wood blank carefully before mounting on chuck/lathe. Only Mount Wood that has no cracks, splits, holes, or any other weaknesses (e.g. rotten or spongy sections). Do not use poorly jointed or laminated wood. Irregular or out of balance stock needs to be turned at the slowest possible speed until it is in balance. Make sure wood is clamped firmly. Follow mounting instructions for different gripping modes and jaw types. In the expansion mode do not use undue force or jaws may split the wood.

Do not exceed maximum guidelines in this manual for wood blank diameters/length set out in this manual for different modes and jaw types.

Check that the wood is securely held in chuck before operation. Check grip by vigorously wrenching wood blank back and forth. If any loosening occurs, re-examine holding area for adequate grip (Following mounting guidelines) and any damage to holding area. Rotate manually to make sure of clearance before switching power on.

DUPLICATOR OR JIGS: Do not use chuck for work holding with a duplicator or jigs.

Safe Practice:

CHISEL USE: Use only handheld woodturning chisels to shape wood being held in chuck. Use the recommended chisel for the job. Use safe and commonly approved techniques.

WARNING: Never attempt to place hands on a moving chuck on a lathe. Wait for the chuck to come to a complete stop before hands are anywhere near the chuck. Trying to grab at a moving chuck could result in SERIOUS INJURY. Jawslides: For safe operation do not extend the jawslides beyond the chuck body under any circumstances.

Wherever possible stand to one side of the revolving wood.

WEAR SUITABLE CLOTHING: Do not wear any loose clothing, neck ties, gloves, bracelets, rings, or other jewellery that could get caught in moving parts. Wear protective hair covering to contain long hair.

DRUGS, ALCOHOL, MEDICATION: Do not operate chuck or lathe while under the influence of drugs, alcohol, or any medication.

KEEP CHILDREN AND VISITORS AWAY: All children and visitors should be kept safe distance from the work area.

OPENING AND CLOSING OF JAWS

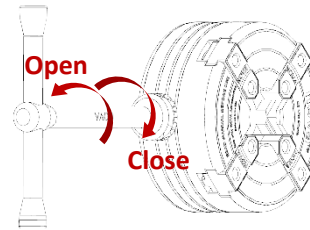

ATTACHING AND REMOVING JAWS FOR LITE G3 CHUCK

The LITE G3 chuck comes included with a set of 50mm add-on jaws.

The jaws must be properly attached on the chuck to function as intended. Before installation, ensure the jawslide top surfaces are clear of any dust or debris before attaching the jaws on the chuck.

Follow the steps shown below to attach the jaws on the chuck:

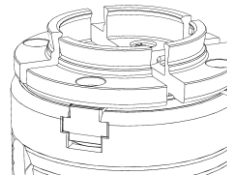

Always mount the jaws clockwise, using the number indented on the underside of the jaw for correct mounting sequence (1,2,3,4).

Loosely attach the jaw segments on the jawslide with the NOVA hex head screw included and firmly close the jaws to make sure no light is visible between the jaw segments.

Firmly tighten the NOVA Hex screws using the included 4mm Allen Key.

To remove the jaws, loosen and remove the NOVA hex screws from the chuck.

Tip: After removal, wipe down the jaws and add rust protection before storing.

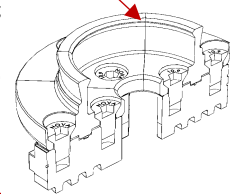

MOUNTING THE LITE G3 CHUCK ON THE LATHE

There are two configurations available for the LITE G3 chuck:

- Insert model: Requires an insert for chuck to be mounted on the lathe. See full manual online for a list of lathe spindle thread inserts available.
- Direct Thread model: Threads directly on the spindle directly available in M33 and 1"8TPI.

1. If the chuck is an insert model, ensure the insert is fully seated in the chuck body before mounting on the lathe.
2. For both Insert & Direct Thread model: Thread the chuck on the lathe spindle until the chuck comes firmly in contact with the bearing/spindle shoulder with no gaps between.
3. Place the red thread protecting fibre washer into the M6 threaded hole. Then screw the 6mm grub screw in position and tighten with the provided 3mm Allen Key to prevent the chuck from loosening on lathe spindle.

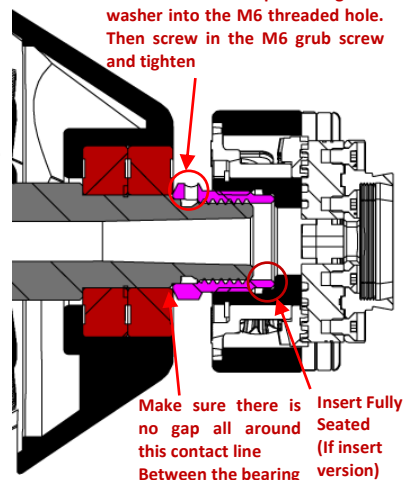

*Using the ASR M33 Thread locking ring (Only applicable to ASR M33 model)

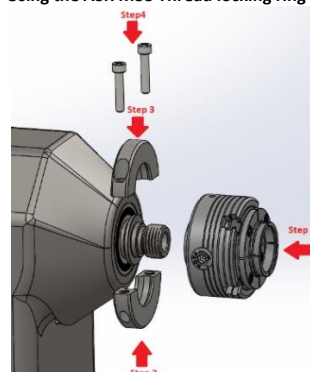

- Step 1:**
Tighten the ASR M33 chuck to the spindle on the lathe, make sure the rings on the spindle and chuck have been clamped.
- Step 2:**
Put the lower part of locking ring under the clamped rings.
- Step 3:**
Put upper part of the locking ring to the clamped rings as well.
- Step 4:**
Using the Allen key to tighten up two bolts on the locking ring.

SCREW CHUCK - WOODWORM SCREW

The woodworm screw provides a convenient method for holding a bowl blank to cut a recess to mount on the LITE G3 50mm (2in) jaws. Jaws must be mounted on the chuck before the woodworm screw – See diagram. (Some models Woodworm sold separately).

Open the jawslide and insert the woodworm screw in the centre hole of the chuck.

Position the woodworm screw as shown in illustration.

Note: All 4 flat sides of the woodworm screw should be in contact with the flat end of the jawslides.

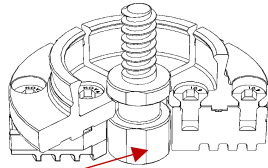

Make sure this flat face is in contact with the tip of the jawslide

The woodworm screw is used to secure the wood to cut either a mortise or tenon on the open 'face' end.

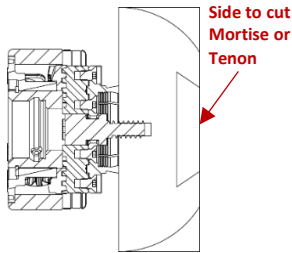

Pre-drill a hole of size 8mm (5/16in) diameter with 19mm (3/4in) depth to mount the blank using the woodworm screw. The wood must be seated firmly and flat against the top surface of the mounted jaws. For first stage rounding of bowl blanks, extra support can be used with live centre support from the lathe tailstock. See full manual online for more details.

DO NOT USE WOOD BLANKS LARGER THAN 250mm DIAMETER X 100mm DEPTH (10inx4in)
DO NOT EXCEED 600-700RPM for 6" and larger, or heavy work pieces

FORMING A MORTISE OR TENON

Mortise



Using a NOVA Dovetail Chisel SKU 6008 (or any other suitable tool), cut into the wood, rest the flat side of the chisel on the bottom surface of the recess to form a dovetail profile of between 75°-80deg with 10mm (25/64in) depth.

Tenon

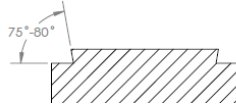

Using a suitable chisel, turn the outer diameter of the wood to form the tenon. The length of the tenon should be 3mm less than the internal height of the jaws.

TURNING ON A MORTISE OR TENON

Tenon is where the jaw contracts onto the workpiece to grip. This is mainly for box, goblet and vase turning (End grain items with a fair degree of overhang).

EXTREME CAUTION WITH THIS OPERATION MUST BE EXERCISED. DO NOT EXCEED 700 RPM FOR THIS OPERATION.

Tennon Diameter (For 50mm Jaws)		
	Min Diameter	Max Diameter
Cylinder	45mm (1 3/4in)	65mm (2 9/16in)
Square	40mm (1 9/16in)	50mm (2in)

Mortise is where the jaw expands into a recess of a workpiece to grip. This operation is mainly for bowl and platter (Items with parallel wood grain).

MUST NOT BE USED FOR ANY LONG WORK (OVER 100mm or 4 inches). DO NOT EXCEED 700RPM! OUT OF BALANCE STOCK MUST BE TURNED AT THE SLOWEST SPEED POSSIBLE.

Recess Mortise Diameter (For 50mm Jaws)	
Min	Max
50mm (2in)	70mm (2 3/4in)

ACCURACY

The LITE G3 Chucks are sample tested from each batch and are made to run within the following tolerance limits on the 50mm (2in) jaws:

- Maximum Face/Axial Runout: 0.08mm (0.0031 in)
- Maximum Radial Runout: 0.15mm (0.0060 in)

However, wood is a flexible material with varying densities and liable to warp while turning.

Under these circumstances pursuing accuracies as above, measured on the wood project clamped in the chuck, can be very difficult to achieve. For most wood turning projects there is usually little requirement to achieve such tolerances.

See trouble shooting guide for detailed guide on accuracy in full manual online at www.teknaatool.com

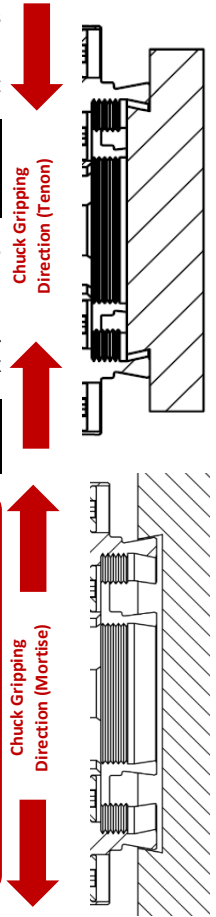

WARRANTY

Your NOVA LITE G3 Chuck is covered by a 10-year Limited Warranty. Go to www.teknaatool.com for a full warranty statement in full version manual LITE G3 Chuck. The full online manual also covers trouble shooting, maintenance, list of NOVA lathe spindle thread inserts, jaw and chuck accessories.

CONTACT
• Teknaatool International Ltd. Phone: (+64) 9 477 5600 • Teknaatool USA. Phone: 727-954-3433
CUSTOMER SOLUTIONS
For all worldwide inquiries, Repairs or Services (issues must be in writing) Go to: www.teknaatool.com/support
Or you can contact the retailer where you purchased your NOVA Chuck, for the contact details please see our website www.teknaatool.com



This chuck is compatible with all NOVA jaws including the jaws shown above.
Note: Excluding jaws that are specific for NOVA Titan chucks



Optional Accessory Jaws



LITE G3

NOVA

LITE G3 CHUCK

Designed and manufactured by
Teknaatool International, Teknaatool, USA, Inc. &
PRC © 2024 Teknaatool

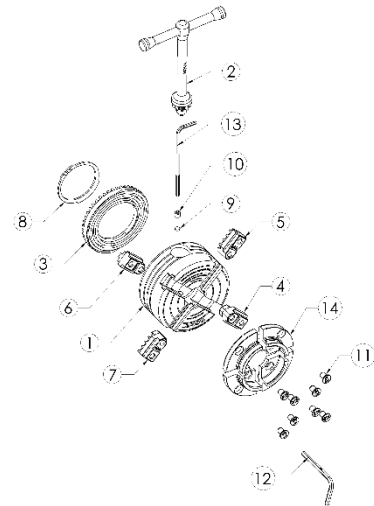

REF#	QTY.	PART#	DESCRIPTION
1	1	48206 / 48239 / 1359011	Chuck Body: Insert type / 1" x8tpi / ASR M33
2	1	1359010	Jaw Scroll Chuck Key
3	1	23109 / 23113	Scroll Ring: Insert type / ASR M33
4	1	1359051 / 1359055	Jaw Slide #1: Insert type / ASR M33
5	1	1359052	Jaw Slide #2
6	1	1359053	Jaw Slide #3
7	1	1359054	Jaw Slide #4
8	1	EC48 / EC50	Circlip: Insert Type / ASR M33
9	2	NS1000	Fibre (Washer) WAD
10	1	G0606	6mm grub screw
11	8	CM5010181	NOVA Hex Screws - C/Sunk
12	1	AK4	4mm Allen Key
13	1	AK3	3mm Allen Key
14	1	10029	50mm Jaw Set