

INSTRUCTION MANUAL

NOVA
DVR XP TM (Xtra Performance)

WOODLATHE



Publication 115-0214-004

Models

- 1) 55175 spindle thread 1 1/4" x 8 tpi 115v
- 2) 55180 spindle thread M33x3.5 220-240v (Europe)
- 3) 55177 spindle thread 1 1/4" x 8 tpi 220-240v (Australasia)
- 4) 55178 spindle thread 1 1/4" x 8 tpi 220-240v (UK)
- 5) 55181 spindle thread 1 1/4" x 8 tpi 220-240v (South Africa)

Nova DVR XP Lathe Features at a glance

DVR Electronic drive

The Nova DVR XP lathe is unique. The DVR incorporates the motor built as part of the headstock, the spindle and motor are one unit. The motor is almost maintenance free and designed with high reliability. The Digital Variable Reluctance motor uses smart motor technology to provide an incredibly smooth and powerful drive. This drive takes turning to a new level. The controller monitors the spindle position constantly and maintains spindle speed very closely. Additional power is added as it senses extra load from the tool.

Add on Bed System

A lathe that meets your woodturning needs your workshop space, and your pocket! Each segment is 20" or 510mm in length. This feature appeals for many different reasons:

- As a compact lathe (standard configuration) it is great for small turning workshop spaces.

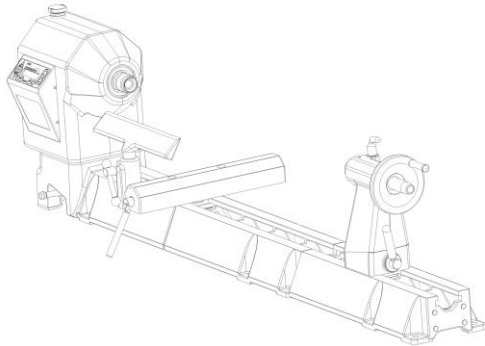

DVR XP extended lathe (Standard model plus one bed segment)

- As an extended lathe for those wanting to do extra long spindles (beyond the traditional between center of most lathes) the Nova DVR XP delivers big turning capacity.
- As a bowl lathe for those just wanting to turn bowls.

Sophisticated Swivel Head

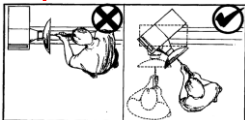

Swivel head lathes have many advantages:

- Space saving
- Allows the turner (not the machine!) to decide the most comfortable position for your turning (saving you from backstrain)
- Elimination of left-hand 'outboard' turning techniques and no extra outboard chucks and faceplates are necessary.

There are a number of swivel head lathes available, but the Nova DVR XP has by far the most sophisticated, accurate and easy to use swivel head on the market.

The Nova DVR XP lathe can be easily and quickly swiveled to any position (360 degrees). It can be solidly locked in any position plus it has the added security of a detent pin lock at 0,22.5,45,90 degrees plus 315 (for left-hand use).

The swivel head turns, locks easily and has a very accurate detent position, to lock the spindle in line with the tailstock. The combination of rigid Tailstock construction and detent pin delivers superb accuracy and is unique to the Nova DVR XP.

Solid Construction

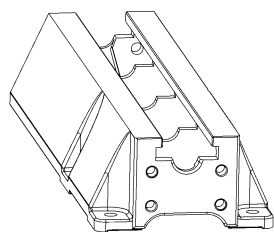

Bed Extension Segment

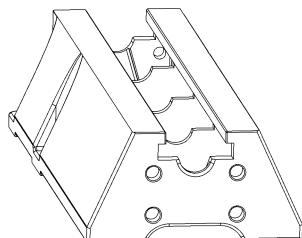

Main Bed Segment

Well proven design, the Nova DVR XP is made from Cast Iron components for strength and rigidity. Added features like the heavy duty TRIMAX triple bearing system and special webbed bed design makes the lathe well equipped to take heavy turning stresses. The bed has been designed with vibration dampening qualities - a solid 1/2" cross rib is positioned along the bed unit, quickly dissipating any vibration as it travels down the bed. The new powerful trapezoidal bed design delivers even more vibration damping properties. All this combined with cosmetically appealing, smooth flowing lines.

Cast iron has always been the material of choice for Woodlathe construction for its inherent mass and an excellent modulus of vibration.

New 5 Favourite Speeds Function

Pre-program your most favourite speeds for easy retrieval.

New Trapezoidal Bed Design

Powerful with smooth flowing lines, new bed design delivers even more vibration dampening properties.

New Headstock Design

One piece design increases strength and vibration dampening properties. Micro analysed for optimum design. Same popular swivel headstock as used in the older DVR and 3000 Lathe models, saves strain on your back.

Adaptive Control Software

Smart adaptive computer technology actually measures the weight of the workpiece and adjusts its performance accordingly.

Safety Sensing Feature

Intelligent DVR computer controller senses abnormal turning conditions e.g. a chisel dig in or index left engaged – and instantaneously shuts down power to the spindle. Normal safety precautions would still apply – see pages 7-8.

Energy Efficient

Unlike other 'dumb' electric motors, the Smart DVR Motor only inputs enough power to maintain the set speed – giving you potential for power savings over conventional motors.

Wide Speed Range

100-3500 rpm, easy push button speed change.

DVR Direct Drive Motor

Driven by unique Direct Drive Variable Reluctance Motor Technology, with superior performance over AC or DC motors. Proven technology, many thousands of users. No power loss through belts or transmission. Provides digital electronic push button variable speed with no belt changes.

Ultra Smooth Cutting Power

Selected RPM is closely maintained and the DVR has no belt stretch or motor bounce which affects smooth cutting. The DVR motor runs smooth with almost no vibration.

Trimax Bearing System

Unique Trimax Bearing System is a triple bearing system to provide a smooth, heavy duty load bearing support for the spindle, which can easily absorb turning stresses.

5 Year Warranty (limited)

On all castings, mechanical parts and components. 2 Year Warranty on all electronics and electrical components.

Plug and Play

Just bolt to stand or bench, plug it in and you are turning! No complex motor set ups or adjustments.

Low Maintenance

The motor is simple, brushless with no rotor windings (rotor is solid steel). The industrial grade electronics are built to last. There are no drive pulleys or belts to set up or come loose.

Welcome

Thank you for choosing our Nova DVR XP Woodlathe and welcome to the NOVA product family. Your choice shows you want the best for your woodturning and you recognise the superb DVR drive technology and the host of other unique features the Nova DVR XP offers.

We strive to achieve the best value for your money – providing quality, innovative features, a wide range of accessories – plus comprehensive, ongoing support (latest manuals downloadable from our website, newsletters, projects etc). We are only a phone call or email away with technical advice or assistance on the operation of your lathe or your woodturning queries.

Please feel free to contact us about any aspect of our products or service – we regard our customers as our best development and improvement team – we would love to hear from you!

Once again, welcome to the “NOVA Family”. We trust that you enjoy our products and hope they enhance the pleasure you experience from the wonderful craft of woodturning!

Best Regards

Brian Latimer
Marketing Director
Teknatool International Ltd

Contact NOVA

New Zealand and Rest of the World

Teknatool International Ltd

Phone: (+64) 9 477 5600

Email: service@teknatool.com

Website: www.teknatool.com

United States

NOVA Innovation and Customer Care Center

Phone: 727-954-3433

Email: service@teknatool.com

Website: www.teknatool.com

Or you can contact the retailer where you purchased your NOVA DVR XP Wood lathe, for the contact details please see our website www.teknatool.com

Table of Contents

GENERAL SAFETY RULES	7
ADDITIONAL SAFETY RULES FOR WOODLATHES	8
DVR XP Woodlathe Specifications	9
Workshop Requirements	10
Lathe Stand Recommendations	10
Example of Shop-made Lathe Stand	11
Assembling the Nova DVR XP	12
Nova DVR XP Components After Unpacking	12
Installing the Headstock Lockpin	13
Adding an Extension Bed	13
Mounting the Lathe to a Support Surface	15
Connecting to Power	15
Using the Nova DVR XP	16
DVR Drive Functions	17
Turning Tips	19
Swiveling the Headstock	20
Spindle Index	20
Headstock	21
Spindle Thread Size	21
Toolrest	22
Tailstock	23
Learning Turning	24
CONTROLLER USER'S GUIDE	25
Programming the Favourite Speeds	29
Maintaining the Nova DVR3000	33
General Maintenance	33
Cleaning the Toolslide	34
Cleaning the Tailstock	34
Aligning the Tailstock	35
Voltage selection	36
Troubleshooting Guide	38
Troubleshooting Guide continued	40
DVR XP Woodlathe Parts List	41
Accessories	44
Accessories	45
Index	46

The information and specifications contained herein are subject to change. Teknatool is not responsible for errors or omissions herein or for incidental damages in connection with the furnishing or use of this information.

GENERAL SAFETY RULES



Warning! Failure to follow these rules may result in serious personal injury.

- FOR YOUR OWN SAFETY, READ THE MANUAL BEFORE OPERATING THE TOOL.** Learn the machine's application and limitations plus the specific hazards particular to it.
- ALWAYS USE A FULL FACE SHIELD-Strongly recommended** (must comply with ANSI STANDARD Z87.1 -USA) Everyday eye-glasses usually are only impact resistant and safety glasses only protect eyes. A full face shield will protect the eyes and face. Also use face or dust mask if cutting operation is dusty.
- WEAR PROPER APPAREL.** Do not wear loose clothing, gloves, neckties, rings, bracelets or other jewelry which may get caught in moving parts. Non slip footwear is recommended. Wear protective hair covering to contain long hair.
- USE EAR PROTECTORS.** Use ear muffs for extended period of operation. Use muffs rated to 103 DBA LEQ (8 hour).
- DON'T USE IN DANGEROUS ENVIRONMENT.** Don't use power tools in damp or wet locations, or expose them to rain. Keep work area well lighted. The DVR XP Lathe is intended for indoor use only. Failure to do so may void the warranty.
- KEEP WORK AREA CLEAN.** Cluttered areas and benches invite accidents. Build up of sawdust is a fire hazard.
- KEEP CHILDREN AND VISITORS AWAY.** The Nova DVR XP is **not recommended** for children and infirm. Such personnel and onlookers should be kept a safe distance from work area.
- MAKE WORKSHOP CHILDPROOF** with locks, master switches, or by removing starter keys.
- GROUND ALL TOOLS.** If the tool is equipped with a three prong plug, it should be plugged into a three hole electrical receptacle. If an adapter is used to accommodate a two prong receptacle, the adapter plug must be attached to a known ground. Never remove the third prong.
- MAKE SURE TOOL IS DISCONNECTED FROM POWER SUPPLY** while the motor is being mounted, connected, or reconnected.
- DISCONNECT TOOLS from wall socket** before servicing and when changing accessories such as blades, bits, cutters and fuses etc.
- AVOID ACCIDENTAL STARTING.** Make sure switch is in the Off position before plugging in power cord.
- NEVER LEAVE MACHINE RUNNING UNATTENDED.** Do not leave machine unless it is turned off and has come to a complete stop.
- KEEP GUARDS IN PLACE** and in working order.
- USE CORRECT TOOLS.** Do not use a tool or attachment to do a job for which it was not designed.
- USE RECOMMENDED ACCESSORIES.** The use of improper accessories may cause hazards.
- DON'T FORCE THE TOOL.** It will do the job better and be safer at the rate for which it was designed.
- MAINTAIN TOOLS IN TOP CONDITION.** Keep tools sharp and clean for best and safest performance. Follow instructions for lubricating and changing accessories.
- NEVER STAND ON TOOL.** Serious injury could occur if the tool is tipped or if the cutting tool is accidentally contacted.
- REMOVE ADJUSTING KEYS AND WRENCHES.** Form a habit of checking to see that keys and adjusting wrenches are removed from tool before turning it on.
- DON'T OVERREACH.** Keep proper footing and balance at all times.
- DIRECTION OF FEED.** Feed work into a blade or cutter against the direction of rotation of the blade or cutter only.
- ATTENTION TO WORK.** Concentrate on your work. If you become tired or frustrated, leave it for awhile and rest.
- SECURE WORK.** Use clamps or a vice to hold work when practical. It's safer than using your hand and frees both hands to operate tool.
- CHECK DAMAGED PARTS.** Before further use of the tool, any part that is damaged should be carefully checked to ensure that it will operate properly and perform its intended function. Check for alignment of moving parts, binding of moving parts, mounting, and any other conditions that may affect its operation. Any damaged part should be properly repaired or replaced.
- DRUGS, ALCOHOL, MEDICATION.** Do not operate machine while under the influence of drugs, alcohol, or any medication.
- DUST WARNING.** The dust generated by certain woods and wood products can be harmful to your health. Always operate machinery in well-ventilated areas and provide means for proper dust removal. Use wood dust collection systems whenever possible.

ADDITIONAL SAFETY RULES FOR WOODLATHES



Warning! Failure to follow these rules may result in serious personal injury.
Important: ALWAYS BEFORE SWITCHING SPINDLE ON, CHECK SCREEN FOR CORRECT SETTING

1. **DO NOT MODIFY OR USE LATHE FOR USES OTHER THAN FOR WHICH IT WAS DESIGNED.**
2. **SEEK INSTRUCTION.** If you are not thoroughly familiar with the operation of woodlathes, obtain advice from your supervisor, instructor, or other qualified person. Instruction from a qualified person is strongly recommended.
3. **DO NOT OPERATE LATHE** until it is completely assembled and installed. Follow instructions and recommendations.
4. **FOLLOW ELECTRICAL CODES.** Make sure wiring codes and recommended electrical connections are followed and that the machine is properly grounded.
5. **WHEN REPLACING THE FUSE** (on relevant models), completely isolate power when removing the fuse. It is imperative the plug is removed from the mains supply before the fuse is removed. Replace fuse cap before reconnecting to mains.
6. **DVR XP; Do not open the switch and rear covers.** Components can carry dangerous voltages even when isolated from mains power.
7. **DVR XP; Always ensure spindle fixtures (e.g. faceplates etc) are locked to spindle in case spindle reverse is engaged.** Otherwise they will unwind from spindle. See "Mounting a Faceplate to a chuck" section.
8. **WHEN SPINDLE REVERSE IS ENGAGED DO NOT USE CHISELS OR CUTTING TOOLS - USE FOR SANDING ONLY**
9. **KEEP WORK AREA CLEAN.** Do not turn the lathe on before clearing the lathe of all objects (tools, scraps of wood, etc.). Keep the nearby area and floor clear of debris.
10. **CHECK SET-UP** with spindle Off. Examine the set-up carefully and rotate the work piece by hand to check clearance and check speed is correctly selected before turning on spindle.
11. **DO NOT MAKE ADJUSTMENTS** when the lathe or work piece is turning. Make all adjustments with power Off.
12. **TIGHTEN ALL CLAMP HANDLES** on the headstock, tailstock, and toolrest before operating lathe.
13. **EXAMINE WORK PIECE** and glue joints before turning to make sure it has no defects that would cause it to break when turning.
14. **DVR XP; ALWAYS CHECK CORRECT SPEED IS SELECTED BEFORE SWITCHING ON SPINDLE**
15. **USE LOWEST SPEED** when turning a new or unbalanced work piece.
16. **TURN AT RECOMMENDED SPEED.** Always operate the lathe at the recommended speeds. Consult this manual for suggested speeds.
17. **ADJUST TOOLREST** close to the work piece. Before turning, revolve the stock by hand to make sure it clears the rest. At intervals, stop the lathe and readjust the toolrest.
18. **KEEP TOOL ON TOOLREST.** The lathe tool or chisel should be on the toolrest before the lathe is turned On. Tools should remain on the toolrest whenever the tool is engaged in contact with the work piece **REMOVE TOOLREST** when sanding or polishing so fingers do not get pinched.
19. **USE CORRECT LATHE TOOLS.** Do not use spindle turning chisels for faceplate mounted work, and vice versa. Spindle turning tools used for faceplate mounted work may grab the work piece and pull the chisel from your control.
20. **WHEN ROUGHING STOCK** do not jam the lathe tool or chisel into work piece or take too big a cut.
21. **DO NOT POUND WORK PIECE** into headstock drive (spur) center when turning between centers. Pound the drive center into the work piece with a soft mallet before installing it between centers in the lathe.
22. **DO NOT USE TAILSTOCK** to drive work piece into the drive (spur) center when turning between centers. Secure work between centers with light pressure from the tailstock quill action.
23. **FASTEN STOCK SECURELY BETWEEN CENTERS.** Make sure the tailstock is locked before turning on the power.
24. **NEVER LOOSEN TAILSTOCK SPINDLE** or tailstock while work piece is turning.
25. **CORRECT USE OF FACEPLATE.** When faceplate turning, make sure work piece is securely fastened to the faceplate and that appropriate size faceplate is used to support the work piece. Any screw fasteners must not interfere with the turning tool at the finished dimension of the work piece. Rough-cut the work piece as close as possible to finished shape before installing on faceplate.
26. **DO NOT OPERATE LATHE IF DAMAGED OR FAULTY.** If any part of your lathe is missing, damaged or broken, in any way, or any electrical component fails, shut off the lathe and disconnect the lathe from the power supply. Replace missing, damaged, or failed parts before resuming operation.
27. **ADDITIONAL SAFETY INFORMATION** regarding the safe and proper operation of this product is available from the National Safety Council, 444 N. Michigan Avenue, Chicago, IL 60611 in the Accident Prevention Manual of Industrial Operations and also in the Safety Data Sheets provided by the NSC. Also refer to the American National Standards Institute ANSI 01.1 Safety Requirements for Woodworking Machines and the U.S Department of Labor OSHA 1910.213 Regulation.

Guidelines to symbols used in this manual:



Warning Symbol. Pay close attention!



Note/Information Symbol. Please read - important information for you.

DVR XP Woodlathe Specifications

Size: 1100mm(L) x 240mm (W) x 412mm(H)
43 1/3"(L) x 9 1/2" (W) x 16 1/4"(H)

Weight: 82kg (181 LB)

Swing Over Bed: 400mm (16in.)

Distance Between Centers: 600mm (24in.);
extendable in 510mm (20in.) units with
add-on Bed sections.

Swing Outboard: 740mm (29in.) with headstock
at 90° using outrigger toolrest.

Headstock:

Spindle Thread: M33 x 3.5 RH ⁽¹⁾ or
1-1/4 x 8 TPI RH ⁽²⁾

Headstock Bore: No. 2 Morse Taper (#2 MT)

Headstock Swivel: 0 to 360 degrees, with
detents at 0, 22.5, 45, and 90 degrees.

Outboard End Internal Thread: M20 x 1.5 LH

Spindle Index: 24 divisions (every 15 degrees) 15mm
through-hole through Headstock

Tailstock:

Tailstock Bore: No. 2 Morse Taper (#2 MT)

Quill Travel: 85mm (3-1/4in.)

Hole Through Tailstock: 15mm (9/16in.)

Toolrest:

Length: 300mm (12in.)

Shaft Diameter: 25.4mm (1in.)

Speeds (rpm):

100 – 3500 (in 5rpm increments)

Favourite Speeds:

5 presets

Standard Equipment:

300mm (12in.) Toolrest, 80mm (3in.) Faceplate* (Not
all countries, see notes below), (Not all countries, see
notes below) Spur Center, and Live Center. Outboard
Handwheel.

Nova 3000 Bowl Lathe Version:

Specifically for bowl turning, does not include bed
extension, tailstock, and centers.

Optional Accessories:

Precision Midi, G3, SuperNova 2 & Titan Chuck

80mm (3in.) Faceplate

Vacuum Faceplate

100mm (4in.) Toolrest

Bowl Toolrest

Outrigger Toolrest Unit

Vacuum Coupler

Revolving Center System

Faceplate rings

Notes:

(1) Applicable to Europe (excluding the UK)

(2) Applicable to United States, Canada, United Kingdom,
Australia, New Zealand & South Africa.

ⓘ* *Note: Standard equipment varies from country to country, In
some markets, the faceplate is an optional accessory. Check with
your reseller if you are unsure.*



For Europe, Australasia, UK and South Africa

Directives this equipment complies with:

Low voltage directive (LVD) 73/23/EEC + 93/68/EEC +2006/95/EC
Machinery directive (MD) 89/392/EEC + 91/368 EEC + 93/68/EEC +
2006/42/EC Electromagnetic compatibility directive (EMCD)
89/336/EEC + 92/31/EEC + 93/68/EEC + 2004/108/EC

Harmonized Standards applied in order to verify compliance with
Directives:

EN 61029-1:2009 (Low Voltage Directive and Machinery
Directive)

EN 55014-1:2007

EN 55014-2:2009

EN 61000-3-2: Ed3 2006

EN 61000-3-3:1995 A1 + A2

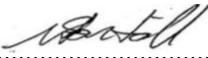
Signed..........Dated 10/12/2010

Nathan Stantiall
Development Manager

Setting Up Your Workshop

Workshop Requirements

<i>Consideration</i>	<i>Recommendation</i>
Lathe location	Locate the Nova DVR XP close to a power source in an area with good lighting. Leave enough clearance on all sides of the lathe; allow for motor clearance when the headstock is swiveled. Other machines in your shop should not interfere with the operation of the lathe.
Lighting	Your shop should have adequate lighting. The work area of the lathe should be well lit; there should not be shadows cast on your work. If possible, locate near a window. A portable spotlight may be helpful.
Electrical	The Nova DVR XP requires the appropriate power outlet nearby to power the motor. Wiring and outlets should adhere to local electrical codes. If in doubt, seek advice from an electrician. Minimize use of extension cords. See "Connecting to power" section for Surge Protector requirements.
Ventilation	Your shop should be adequately ventilated. The degree of ventilation will vary based on the size of the shop and the amount of work done. The use of dust collectors and filters will minimize risks to your health.

Lathe Stand Recommendations

A sturdy and rigid stand is required so that the Nova DVR XP Woodlathe can deliver optimum performance. A common flaw with many woodlathe installations is an inadequate stand for the lathe. The larger the size of your turnings, the greater the importance of the lathe stand design.

<i>Consideration</i>	<i>Recommendation</i>
Lathe Height from floor	The height of the stand should locate the centerline of the lathe spindle at the elbow height of the turner.(illustration next page)
Stand Top	The stand top should be flat so the lathe does not twist when it is bolted down. Check for any gaps between lathe feet and stand top before bolting down. Shim and prepare stand as necessary.
Stand Weight	The stand should have enough weight and mass so that it doesn't move when turning large work pieces, and so that the stand can absorb vibrations. A lathe stand's stability can be improved by weighing it down with sand bags on a lower shelf.
Stand Legs	The stand should sit level on the floor and not rock.

Example of Shop-made Lathe Stand

This has been designed with economy of space in mind. Heavier sections, wider rails and gussets on the corners are encouraged. For stability and vibration dampening, it is highly recommended that the base is filled with sand.

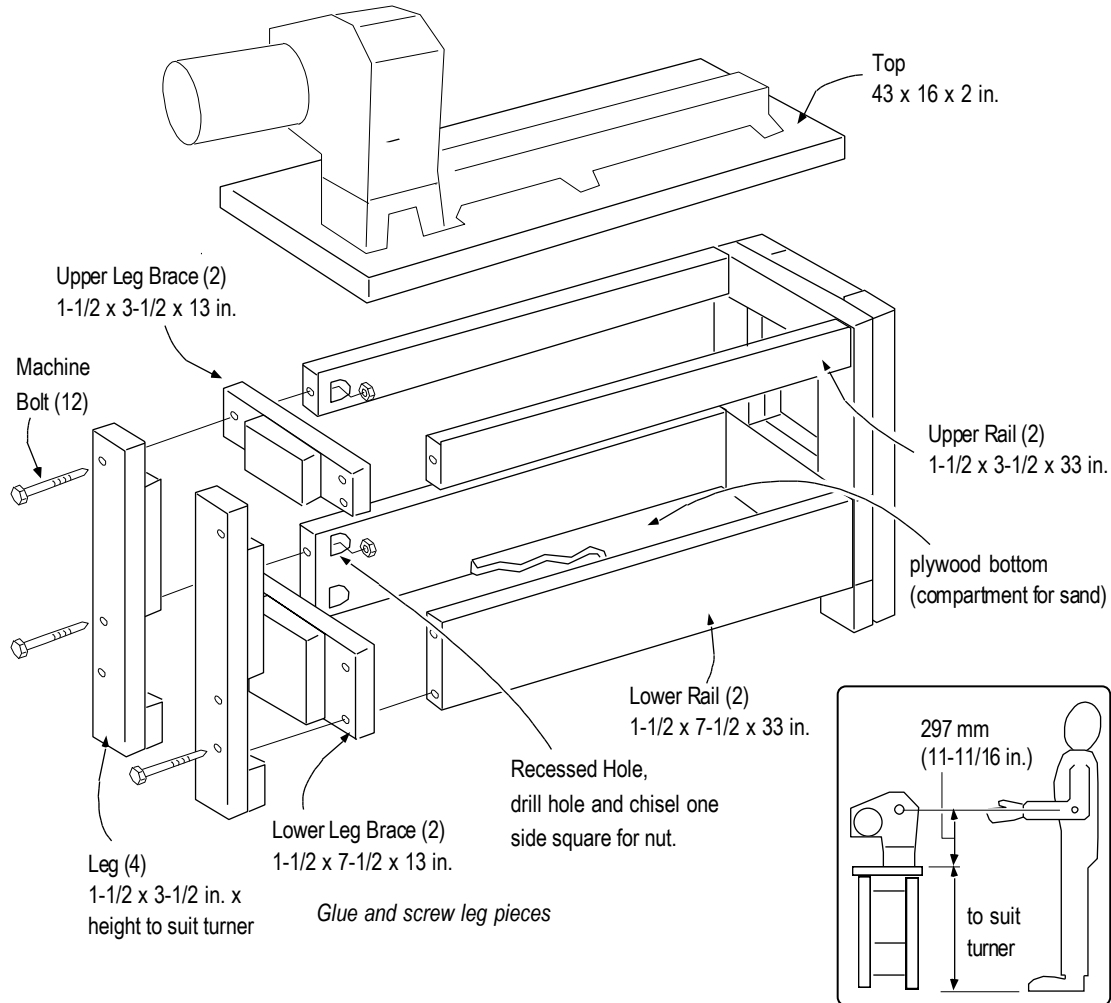

Assembling the Nova DVR XP

1. Unpack the lathe and components from the shipping container. This is best done by cutting down the sides of the box to expose the lathe



Warning!

Have other people help when moving or lifting the Nova DVR XP Woodlathe; it weighs about 82kg (181 LB).

2. Clean any parts coated with rust preventative with a cloth moistened with a petroleum-based solvent or cleanser, such as paint thinner. Coat the lathe bed with paste wax.

Nova DVR XP Components After Unpacking

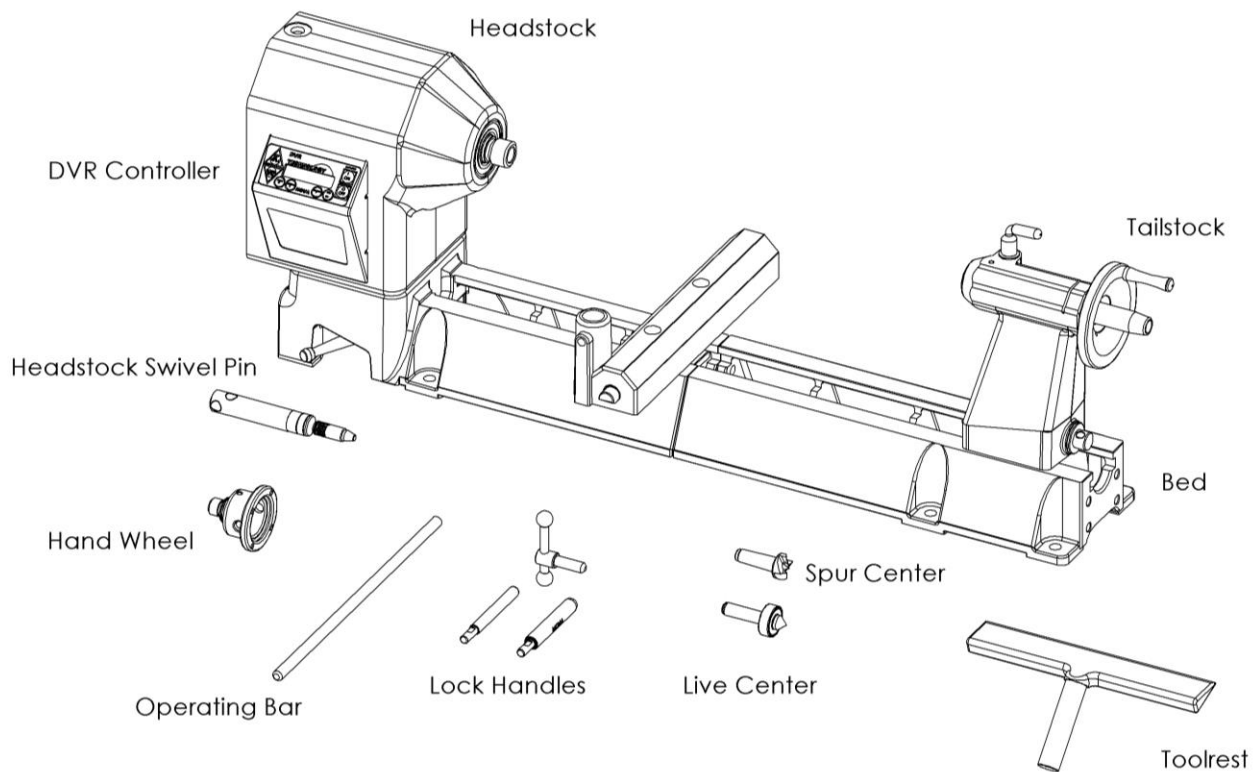

Installing the Headstock Lockpin

- Remove the plastic shipping tube from headstock base. Immediately screw the Headstock Lockpin into the threaded hole at the bottom of the headstock. Insert the operating bar into the hole in the Lockpin and firmly tighten the Lockpin to lock the headstock in position; then remove the operating bar. **NOTE:** When the pin is fully engaged the groove machined into the pin furthest from the thread should line up with the edge of the hole in the casting. By doing this the pin will be engaged in the hole of the swivel pin.
- Loosen the Lockpin 1 – 2 turns. Push the Headstock Release Handle down and rotate the Headstock so the spindle points to the tailstock and lines up parallel to the lathe bed. Tighten lock pin again.

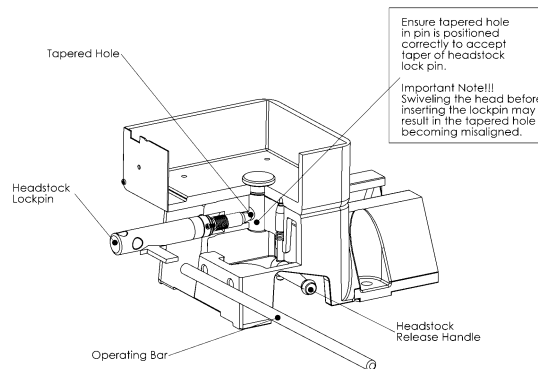

Important note: Swiveling the head before inserting the lock pin may result in the tapered hole on the Swivel pin becoming mis-aligned.

ⓘ Note: Do not use excessive force when tightening the Lockpin.

- Assemble the handles:

ⓘ Note: Some handles may come pre-assembled.

Toolrest Clamp Handle - insert the rod through the handle and screw the ball knobs onto each end of the rod.

Toolslide Clamp Handle - screw the lock handle into the toolslide.

Tailstock Clamp Handle - screw the lock handle into the tailstock.

Installing Handles

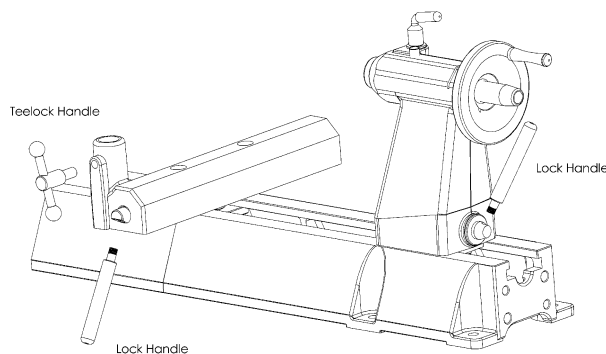

Adding an Extension Bed

Each cast iron extension bed adds 510mm (20in.) to the lathe's capacity to turn between centers.

- Clean the joining ends of both bed sections with a petroleum-based solvent. Make sure there are no dents or burrs on either mating surface. Remove burrs and high spots with a smooth file.
- Screw in cap screws tight
- Secure the bed sections together with four M12x30 cap screws using a 10mm Allen wrench. It may be necessary to move the lathe so the cap screws can be reached

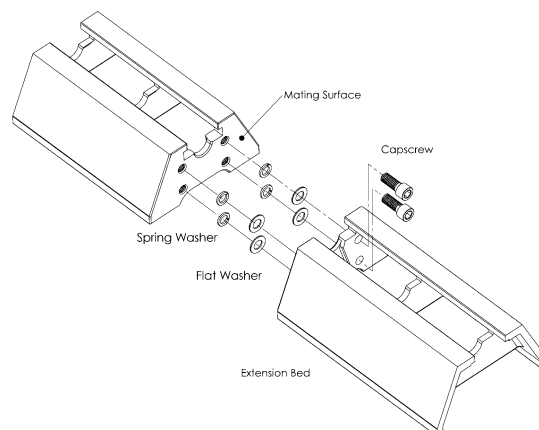

with the wrench from the bottom of the bed.



Warning!

Do not use a metal hammer to pound on the extension bed. This may damage the bed, affect accuracy and tailstock action, and may prevent you from adding another extension bed.

4. Bring the Tailstock along until it is on top of the join area where the bed extension face meets the lathe bed face. The bed extension may need to be manipulated up-and-down and sideways in order for the Tailstock to fit.
5. Check that the toolslide and tailstock move freely over the mating joint and also over the full length of the add-on extension. If there is a ridge between the two mating surfaces then repeat steps 1 - 4 again, use a smooth file to file the surfaces flush.
6. Follow the suggestions under "Mounting the Lathe to a Support Surface".

Mounting the Lathe to a Support Surface

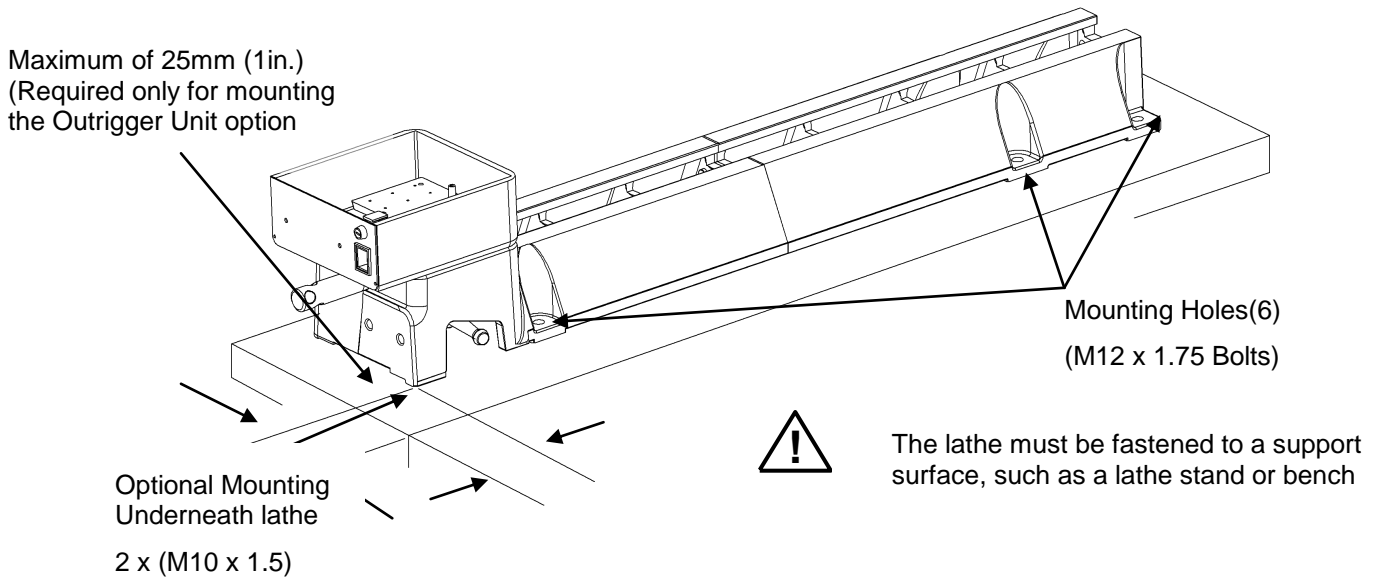

1. Place the lathe on the stand top. Locate the front and left corner of the lathe approximately 25mm (1in.) from the corner edge of the stand top. This provides a comfortable reach when turning and allows the optional outrigger unit to be easily installed.
2. If necessary, mark the six hole locations on the top and drill M12 holes.
3. Place a spirit level along the top of the lathe bed. Any movement of the bubble as the lathe is secured, indicates a twist on the bed. For the lathe to operate correctly the bed must not twist; if necessary, use shims between the bed and stand top.
4. Use bolts of suitable length (not included) to secure the lathe. Tighten the two headstock bolts first, then the two tailstock bolts, and finally tighten the last two bolts on top.
5. The two M10 threaded holes underneath the outrigger end of headstock can be optionally used (making a total of 8 bolt positions). Ensure that the bolt is a metric M10 x 1.5mm pitch and that the length is correct to ensure that the bolt doesn't bottom in the threaded hole and potentially damage casting.

Connecting to Power

The power cord should be 3-wire, having a grounding conductor and a grounding plug. The plug must be plugged into a matching outlet that is properly installed and grounded in accordance with local electrical codes.

The DVR XP can run on either 115v or 220v ~ 240v, **but the voltage must be selected** with an internal jumper (see Voltage Selection page 36). If the lathe is purchased in USA, it will already be setup for 115v operation. All other countries are preset for 220v ~ 240v.



Warning!

Improper connection of the motor can result in a risk of electrical shock.

If it is necessary to use an extension cord, the cord should be grounded. Use the correct wire size for the extension cord, for a given cord length, to avoid power loss and over-heating.



IMPORTANT: A Surge Protection Device rated to at least 15 amps - for USA and Canada, other countries 10 or 15 amps - **must be used** to protect the DVR electronics from electrical spikes or surges, similar to those used on most Home PC's. Ground Fault Interrupters (GFI's) or Residual Current Detectors (RCD's) are helpful and are a recommended protection device for any powertool. They can be used in conjunction with a DVR lathe. Note some makes of GFI may not be compatible

Using the Nova DVR XP

Parts of the Nova DVR XP Woodlathe

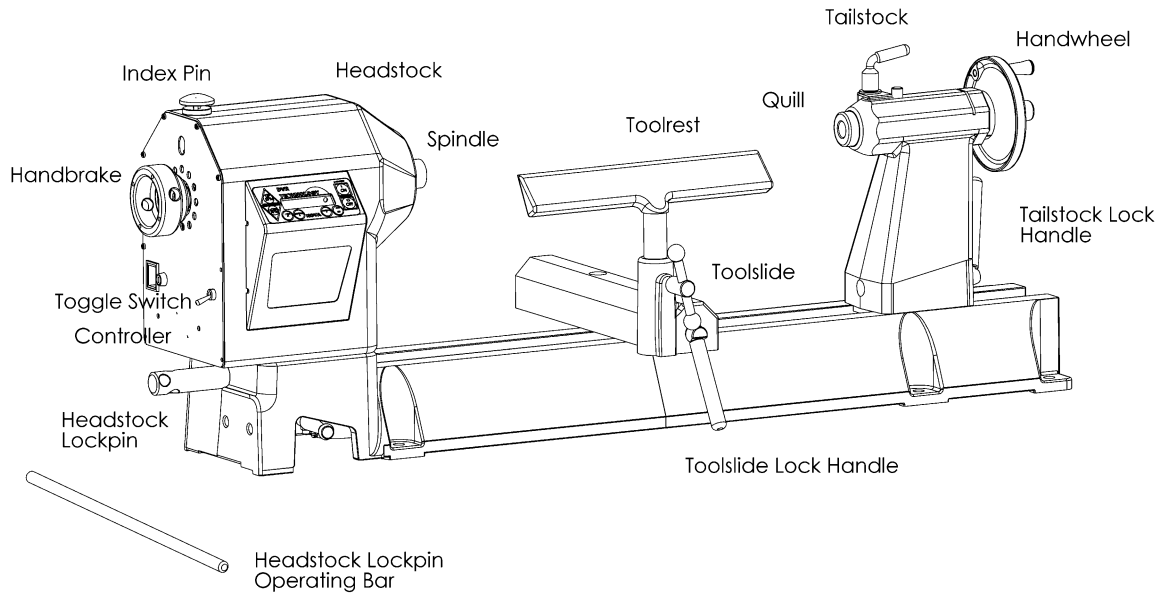

DVR Variable Speed Controller



The Nova DVR XP drive is a unique type of motor and controller where the motor and controller interact. The motor provides data to the controller on its position and load conditions.

The motor provides high torque even at low rpm and inherits extremely close speed control.

With the toggle switch in the Off position, plug lead into wall socket and switch on.

An electronic tune will be heard as the controller computer "boots up" and the LCD display will show a two-line display.

DVR Drive Parameters

Motor Type: Digital Variable Reluctance	Accuracy of Speed Stabilization: <2.5%
Motor Power: 1.75 Hp for 115v, 2.3 Hp for 230v	Regulator Type: PID
Efficiency: > 0.80	Speed Stabilization: Current level, pulse width
Motor Speed Range: 100-3500 rpm	Reverse: Yes
Default speed (when powering up) : 500 RPM	Speed Control: Button (5rpm/increment)

DVR Drive Functions

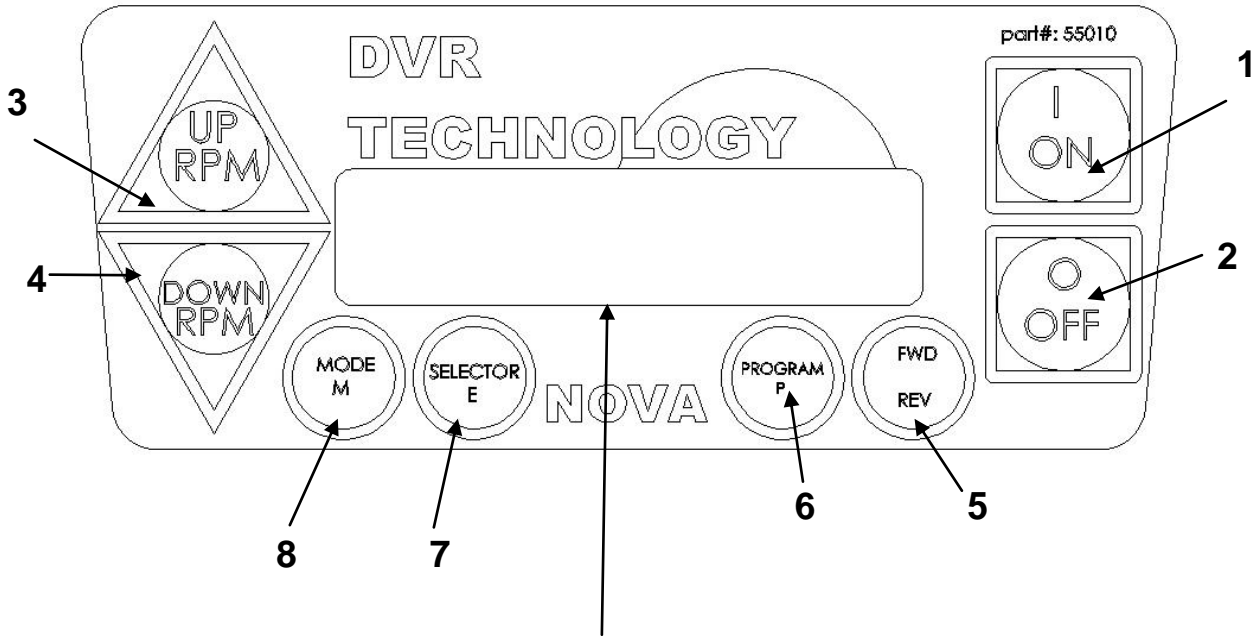

A two-string liquid-crystal display panel (LCD) displays the current information.

Ready to start
at XXXXrpm >>

“XXXX” is the reference motor speed.
“>>” Indicates forward direction of rotation.

1. **Green ON** -- Press to start machine at the commanded speed -- always check that the **speed has been selected correctly**. When the computer is first switched on it is set at a default speed of 500 rpm. Remember that whenever the computer is switched off at the wall or at the incoming power supply switch the computer will restart at the default setting. The spindle cannot restart until 1 “ON” is depressed.

As with any Woodlathe ensure that the index is off and the workpiece is free to turn without hitting the toolrest etc. Ensure that the work piece is secure and the appropriate speed is selected.

Speed = CCCC rpm
Ref -> RRRR rpm

“CCCC” = current value of the motor speed
“RRRR” = reference value. (Value selected)

When the On button is first pushed the screen will display "Go Low!! rpm" and then "4 retries left". These messages are normal, the computer first does a self check.

2. **Red OFF key**. Pressing this key will stop spindle rotation.

The ON / OFF keys in the above panel only switch the motor on and off. The selected speed will remain until adjusted or computer switched off.

3. **UP RPM**. To raise speed, one press of the key will increase speed by 5 rpm. Continuing to hold key pressed will continue to raise speed. The speed can be adjusted with the spindle running or off. To make a large adjustment in speed it is quicker when the spindle is OFF.

4. **Down RPM**. Press to lower speed this key operates the same as up key.

The UP and Down keys can also be used in program mode to change the parameters.

5. **FWD / REV key**. Pressing this key will change the motor rotation from forward to reverse. Pressing again will select forward. You can verify the direction by the two arrows at the bottom left or right of the screen. **Important: always verify the forward or reverse is selected correctly before switching spindle on.**

The Direction of rotation setting is only available in the ready to start mode. Press stop if necessary, and press FWD/REV to toggle direction of rotation. The two arrows on the left side indicate reverse.

Whenever reverse is selected a " Warning Reverse Selected " will flash on screen for about 1-2 seconds before spindle starts.

Special and Parameter settings



You may wish to change the stabilization setting from time to time depending on the type of work piece you are working on. You have 3 options preset for you:

1. SOFT: For light work at speeds lower than 500 rpm
2. NORMAL: Suitable for most work and is the default setting
3. HARD: For heavy and/or 'out-of-balance' work at speeds lower than 500 rpm

a) Press **<OFF>** if necessary.

b) Press **<PROGRAM>** (key #6 on diagram). The stabilization setting will be displayed. The default setting is NORMAL.

c) Press **<SELECTOR>** (key #7 on diagram) to toggle between the 3 options as mentioned above.

NOTE: Pressing **<MODE>** (key #8 on diagram) allows the user to change the parameter settings in more detail. This breaks it down into Proportional (Kprop) and Integration (Kint) settings which make up the PID control of the DVR. The 3 options of SOFT, NORMAL and HARD have been preprogrammed for your convenience and are balanced for optimum output. To clear special settings and return to default --- switch off computer at the master switch.

d) Press **<PROGRAM>** button to return to ready state. (Ready to start mode).

While the machine is running if you push Mode (8) the screen will display various diagnostics. Operation of the machine is not effected. Each time mode is pressed a different screen will show. This area is only used for advanced programming functions.

Auto safety -- If the power is lost to the machine, when power is restored the computer will reboot but the machine will not start until the 'ON' switch is pressed. **Remember to correctly select speed if different from Default speed.**

Warning: Do not push several keys together as special coded combinations of keys open diagnostic and service functions. Some of these disable control and protection functions. If an unfamiliar screen is displayed, switch off the computer and leave for one minute before rebooting.

If the DVR hasn't been used for some period (over one month) it is helpful to switch the unit on 30 – 60 minutes before use

Turning Tips

The Nova DVR XP drive technology is not just a variable speed motor -its smart motor technology takes turning to a new level. The speed, vibration, and load sensing, work with the conditions and turning. The machine will reward skilled turning with exceptional finish conditions. There is often no need for sanding. As you apply load (chisel pressure or depth of cut) the control will sense the change in spindle conditions and compensate accordingly. Get a feel of the communication between yourself and the motor turning by applying increasing force. The motor will respond by applying increased power to exactly maintain speed.

LOW SPEEDS 100-350: Select Hard Mode (see Special and Parameter settings)

Note – at low speeds 100- 350 rpm control of the chisel is important. At 250 rpm the motor still has good torque (in fact the torque is more or less the same as at 400 or 1000 – but at low speeds there is a difference , the DVR is a unique type of motor in that the control only supplies enough power to maintain the spindle at the commanded speed. It needs to sense the load from the chisel and then it will apply power as needed. At very low speeds the chisel can move fast compared with the rotation of the wood. The important thing is to have good control of the chisel and maintain steady cuts (using the same woodturning practices that produce quality cuts and finishes). In this way surprisingly heavy cuts can be achieved. However, rapid or incautious use of the chisel will be immediately sensed by machine and spindle will shut down and then automatically try a restart.

“Will The Machine Shut Down on Interrupted Cuts?” No, as long as the cut is within the normal range of Woodturning cuts. An interrupted cut at slow rpm may cause a loss of control of the chisel and a dig in may occur.

A way to understand chisel feed rates is to consider that at 100 rpm, the work piece has only rotated about 1 and a half turns in one second and at 250 rpm, 4 turns. Considering that chisel feed or movement under normal turning can be anything between say 5 and 100mm per second at normal Woodturning turning speeds. At very low rpms it is easy to move the chisel too fast for good cutting conditions. In general, low rpm is only used for special processes or conditions. Speeds below 350 are generally not Woodturning speeds. The machine will operate down to 100 rpm but this is generally for applying finishes and other applications.

Swiveling the Headstock

1. Stop the lathe. Insert the operating bar into a hole in the Headstock Lockpin. Loosen the Lockpin half a turn.
2. Slide the Headstock Release Handle towards outboard end of lathe, and rotate the headstock to a detent position. Do not push down on the handle.



Warning!

Use the detent latch positions to prevent headstock movement during turning.

4. Firmly tighten the Headstock Lockpin with the operating bar; but do not use excessive force. Remove the operating bar.

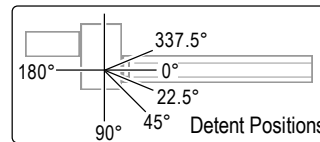
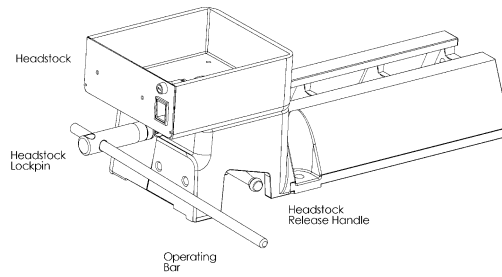

	<i>Right-hand Turners</i>	<i>Left-hand Turners</i>
Detent Positions	0, 22.5, 45, 90 degrees	180, 337.5 degrees

Spindle Index

The spindle index pin locks the headstock spindle. It is selectable in 15 degree increments (24 divisions). There is sight hole to read index numbers (0 through 23).

1. Stop the lathe.
2. Pull the index knob and turn it left until the pin drops into the hole. To lock the spindle it must engage into a hole in the headstock pulley.



Warning!

Make sure the index pin is out before operating the lathe. The pin should drop into the indentation in the headstock to prevent it from engaging while the spindle is turning.

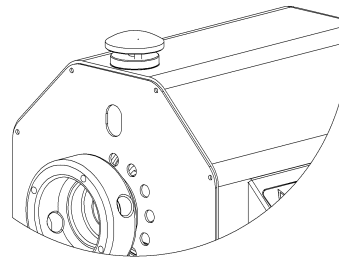

E (1 : 2)

<i>Divisions</i>	<i>Index Number</i>	<i>Degrees</i>
2	0,12	180
3	0,8,16 (every 8th)	120
4	0,6,12,18 (every 6th)	90
6	0,4,8,12,16,20 (every 4th)	60
8	0,3,6,9,12,15,18,21 (every 3rd)	45
12	0,2,4,6,8...22 (every 2nd)	30
24	every hole	15

Headstock

The headstock houses the Rotor, Stator, Electronics, bearings, and the Spindle. The headstock spindle accepts centers and accessories with no. 2 Morse taper (#2 MT), plus threaded faceplates and chucks.

Spindle Thread Size

Country	Threads
United States, Canada, Australia, New Zealand, South Africa, United Kingdom.	1-1/4 x 8 TPI RH
Europe (excluding the UK)	M33 x 3.5 RH

Mounting a faceplate or chuck

1. Use the Spindle Index Pin to lock the headstock spindle.
2. Remove the side-locking screw, then wind the faceplate or chuck onto the spindle threads. A spindle washer in between may be used to make removal easier.



Warning!

The faceplate or chuck body must contact the shoulder on the spindle bearing.

3. Pull and turn the Index Pin and place it in the "safe" indentation in the headstock.
4. A vee groove is provided in the spindle for a special locking grub screw that is used in conjunction with Nova chucks and accessories to prevent unwinding during reverse operations. Wind in the side-locking grub screw and lock firmly in place, without over tightening.



Warning!

It is important that all Chucks and Faceplates that are used on the DVR XP spindles have a side-locking function.

Some older Teknatool products may not have a side-locking function. If any of these products are intended to be used on the DVR XP spindle they will need to undergo a modification to include the side-locking function or new products purchased with a side-locking function. All spindle mounted products produced by Teknatool International for the DVR Lathe have side-locking functions*.

The side-locking function should be used at all times while running the chuck on the spindle during operation. Without this function engaged the Chuck or Faceplate may unwind from the spindle during operation.

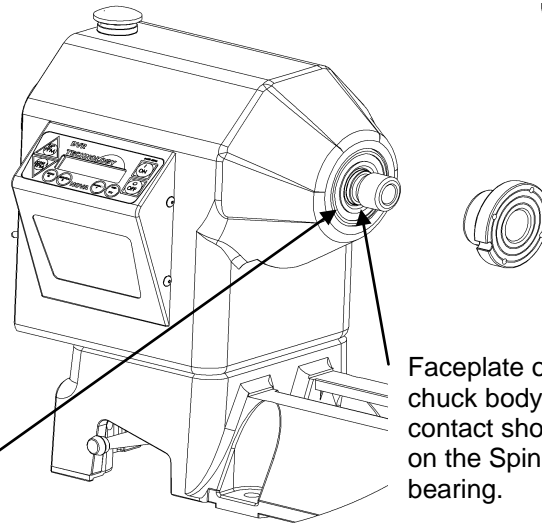

B (1 : 3)



Warning!

When installing or removing the Faceplate or Chuck from the spindle, the side-locking grub screw **MUST** be completely removed.

This avoids any potential damage to the spindle that the grub screw may cause if it were not completely removed, when winding the Faceplate or Chuck on or off the spindle.

**Exception 1.* When an ILNS insert is used with a FP150Z faceplate on the DVR3000 or a Spindle adaptor, the insert or adaptor must be located onto the faceplate to avoid it unwinding when the spindle is run in reverse. Loctite 272 Threadlocker is recommended.

**Exception 2.* Customers with dedicated threaded Teknatool chucks who intend using the chuck on the DVR XP Spindle must have a side-locking function adapted to the chuck before running it. Chucks with M33 threads may apply for Europe.

IMPORTANT NOTE

The Index Pin is designed for indexing and not for leveraging against, when removing faceplates, inserts and chucks. For this we recommend holding the spindle using the operating bar through the 2 LHB holes (Left Hand Brake).

Using a spur center

Mount the spur center to the work piece as shown and then insert the spur center and work piece into the headstock spindle.



Warning!

Do not pound work piece into headstock drive center when turning between centers or you may damage the headstock.

To remove the center, insert a 10mm (3/8-inch) diameter wooden dowel or steel rod through the headstock spindle hole. While holding the center so it doesn't fall, tap it out.

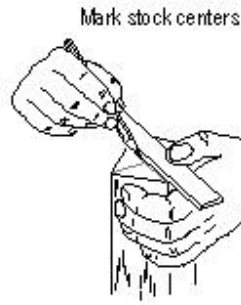

Mark stock centers

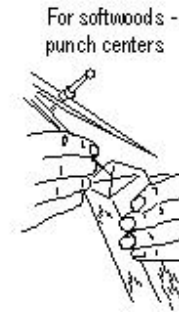

For softwoods - punch centers



For Hardwoods - drill centers and saw diagonals for spur drive centre

Set spur center with mallet

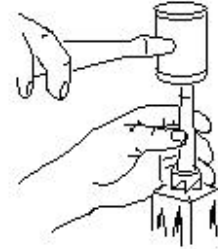

Toolrest

To move the toolrest along the bed, loosen the Toolslide Clamp Handle, move the slide to the desired position, and tighten the clamp handle.

To adjust the toolrest, loosen the Toolrest Clamp Handle, position the toolrest, and tighten the clamp handle.

Adjust the toolrest close to the work piece. Exact positioning may be varied to suit the turner. Before turning, revolve the stock by hand to make sure it clears the rest. At intervals, stop the lathe and readjust the toolrest.



Warning!

Lathe tools and chisels should remain on the toolrest whenever the tool is in contact with the work piece.

Remove the toolrest when sanding or polishing so fingers do not get pinched.

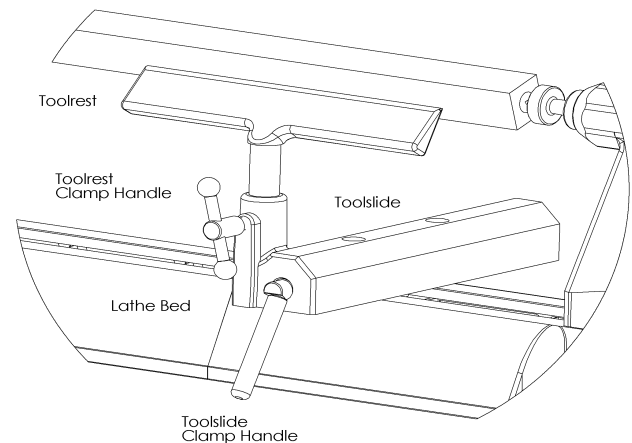
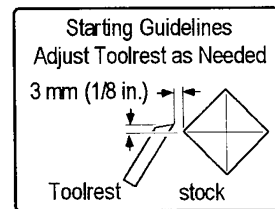

Lathe Turning speeds

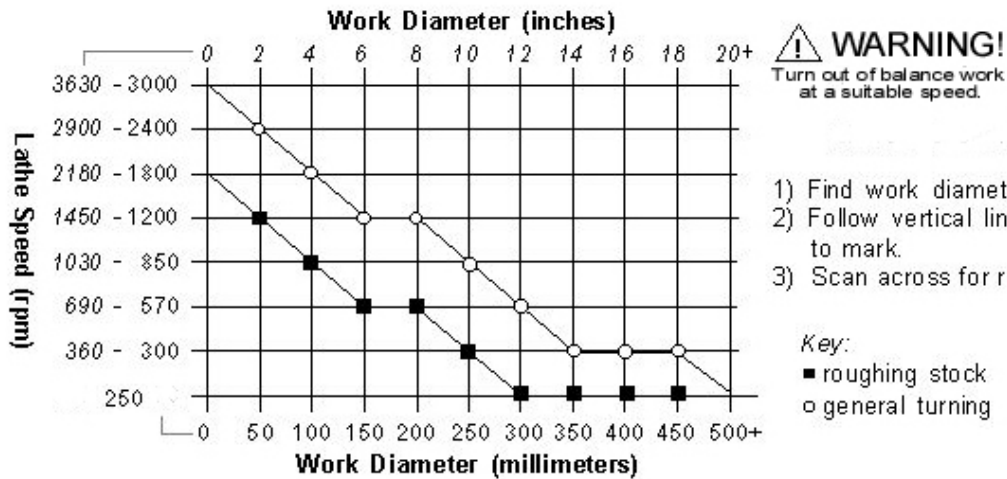

Correct selection of turning speeds is important for safety and finish cut quality

It is important to take into account the fixing of the work piece, it should be made as secure as possible. Various techniques are available for this consult books on the subject and seek training opportunities.

There are safety and out of balance considerations. Aim for a good balance in turning speed, ensure good fixing and try to balance timber as much as possible before installing on lathe.

In general wood likes being sliced and if too low a speed is used the timber can "hammer" against the cutting tool, tearing fibers and imposing large forces on the tool and work piece. This can often be dangerous, it is best to select a higher speed, the cut will be smoother and less force is imposed on the work piece. It can be likened to a wood plane, if it is pushed very slowly much force is needed to break the fibers, if the plane is pushed at a higher speed less forces are involved and a better cut results. Use 250 rpm when needed, but it is better turning at 400-600 rpm.

Tailstock



Warning!

Never loosen the tailstock quill or tailstock while the work piece is turning.

To move the tailstock along the bed, loosen the Tailstock Clamp Handle, slide the tailstock to the desired position, and tighten the clamp handle.

To move the tailstock quill in or out, loosen the Quill Lock and turn the Handwheel. Lock the quill in place with the Quill Lock.

The tailstock quill accepts centers and accessories with no. 2 Morse taper (#2 MT). To install a taper use a quick, firm action by hand. Do not pound the taper in.

To remove a taper, insert the operating bar through the tailstock quill hole. While holding the taper so it doesn't fall, tap it out.

The tailstock quill is hollow, allowing you to bore holes through turnings if a hollow center is used.

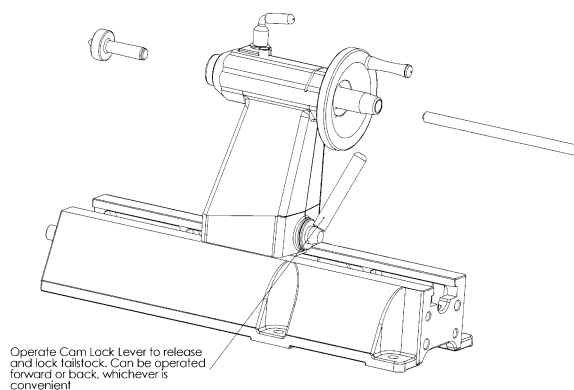

Learning Turning

The art and technique of turning is a subject beyond the scope of this instruction manual. It is recommended that you receive hands-on instruction on lathe turning and/or refer to books and videos on the subject. For reference, some woodturning books are:

The Lathe Book
By Ernie Conover

Woodturning A Foundation Course
by Keith Rowley

Creative Woodturning
by Dale Nish

Turning Wood With Richard Raffan
by Richard Raffan

The Fundamentals of Woodturning
by Mike Darlow



CONTROLLER USER'S GUIDE

NOVA DVR (SWITCHED RELUCTANCE) DRIVE

Control Software versions 4 . 54x

Interface Software version s03

Teknatool International

13th July 2006

1.0 INTRODUCTION

1.1 General

This guide contains the basic information on use of the Digital Variable Reluctance (DVR) electrical drive for DVR 3000/XP lathe.

1.2 Overview

The DVR integrated electrical drive system contains the DVR motor with the Rotor Position Sensor (RPS), the drive control board and the human-machine interface (HMI). The control board, RPS and HMI represent the control system of the drive. The DVR is connected with the control board by six power wires and RPS cable.

The control board contains power input devices - input rectifier, power factor corrector with the DC link reactor, three-phase inverter and the control circuit based on the 16-bit Infineon microcontroller.

The HMI contains the interface board, the LCD and keyboard. The interface board is based on the 8051 family Atmel microcontroller and connected with the control board through the insulated serial RS232 interface.

Both microcontrollers have flash program memory. The interface board microcontroller also contains the EEPROM memory in order to change and store the drive parameters. The control system has been specifically designed for control flexibility and to provide optimal drive performance.

2.0 MAIN PARAMETERS AND FEATURES

- The motor type – Switched Reluctance Motor (DVR)
- Nominal operating output power –1.25 -1.5 kW (2 HP 220V)
- Power supply range: 115V 60Hz/ 230V 50 Hz
- Power factor correction: $PF \geq 0.95$
- Speed range: 100 – 3500 rpm
- Smooth speed setting by keys
- 5 preset (favorite) speeds with save function.
- PI speed controller with adaptive coefficients
- 3 preloaded coefficient curves: SOFT, NORMAL and HARD
- Load inertia measurement for improving the PI speed controller coefficients
- Reverse function
- Torque and speed ramp functions
- Overload protection
- Under-voltage / PFC fault protection

3.0 HUMAN MACHINE INTERFACE DESCRIPTION

The Human Machine Interface (HMI) provides a flexible choice of the drive parameters: run/stop, motor speed, direction of rotation, PI speed controller coefficients. HMI contains 2-lines, 16-position LCD display and keyboard. The drive parameters can be set by decreasing/increasing values incrementally. Some parameter values can be stored in the EEPROM of HMI.

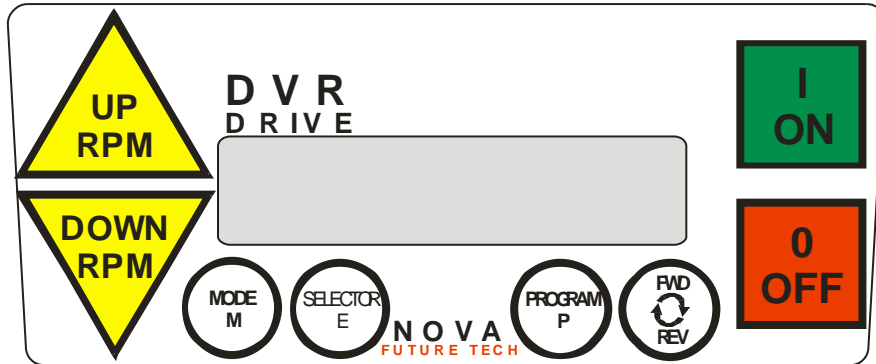

Figure 1: Keyboard view

3.1 Keyboard Description



The keys description:

Key view	Legend	Short Description
	I	- START KEY - - run the motor -
	O	- STOP KEY - - stop the motor and reset system -
	R	- REVERSE KEY - - change the direction of motor rotation -
	P	- PROGRAM KEY -
	E	- SELECTOR KEY -
	M	- MODE KEY -
	S	- UP KEY and DOWN KEY - - Increase/Decrease and set the parameter incrementally -



4.0 CONTROL FUNCTIONS

Drive Parameter Settings (Set Function)

HMI display lines contain the parameters, which can be edited.

Press key  to incrementally increase the parameter or  to decrease it.

Hard Reset Function

Press key , hold it and then press key  in order to provide the Hard Reset of the drive. Another way is to switch off the power, wait 10 seconds and switch it on again. Use this function if you want to return the factory-preloaded values of the drive parameters. Also, try to use this function if you have a problem with the drive, for example, if the system is not responding to the keys.

5.0 CONTROL OPERATIONS AT STOP MODE

5.1 Starting operation

Insert the drive power plug into the 220-230/115v, 50/60 Hz socket. There must be the sound signal and display messages step-by-step will be: (shown on the next page)

TEKNATOOL Int. v4.54xs03 2006

TEKNATOOL PROMO-
TES SAFETY FIRST

ALWAYS WEAR
FACE SHIELD

ENSURE CORRECT
SPEED SELECTED



Beeper will sound twice. Wait for end it or press key  to cancel. After that the display message will be:

TEKNATOOL Int.
v4.54xs03 2006

The version number means:

- v4.54 - control software version
- x - XC164CS Infineon microcontroller with flash memory
- s - Serial interface
- 03 - Interface software version

Note: This guide is updated for the **v4.54x** control software versions and **s03** interface software version, which are compatible with each other. The control software versions **v4.41x** and higher will also work but without some functions.

The drive will make the preparation procedure, check the fault conditions and after that the LCD will show the **Main display page** (for Stop operation):

LCD View	Comments
Set 500rpm=#2D	S Reference speed and number (D = default speed number)
Ready to run >>	R <</>> - reference direction (forward/reverse)

Note: **s** = parameter can be modified using **Set Function**.
R, P, E, M = parameter(s) can be modified by one of keys in accordance with the keyboard description legend (see above).



The drive is in **Stop** mode and ready to run the motor forward with the speed of 500 rpm.

5.2 Reference speed setting. Preset (favorite) speed selection and set function

There are 5 preset speeds available in the drive.
The factory-preloaded reference speeds are:

Number	#1	#2D	#3	#4	#5
Speed (rpm)	250	500	750	1020	1250

Note: The speed #2 is default speed number.
The letter **D** after the number #2 indicates it is default.

- Press the key , hold it and press  or  in order to go from one preset speed number to the next one.

If the next preset speed is higher than 500 rpm, you will see warning:

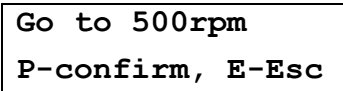
LCD View	Comments
	S Preset speed

Press the key  to confirm the choice or  ("Escape") to return to previous speed.

- Use the **Set Function** (see 4.0) in order to increase/decrease the reference speed. In this case, if the reference speed is not equal to the preset speed of the current speed number, the symbol '=' will be removed from the LCD. For example, if you will decrease the reference speed using key

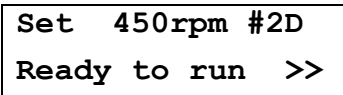

, the LCD will be:

LCD View	Comments
	S Reference speed is now not equal to preset speed #2 R >> - forward direction

If you go back to the speed 500 rpm using key  then the symbol '=' will show on LCD.

- Pick a preset number you would like to change. **IMPORTANT Note:** The default speed (#2D) can not be set at more than 500 rpm and the saved preset speed values will work also after Hard Reset Function.



- Press the key  in order to make the request for saving the new value of pre-selected speed in the EEPROM (memory). It will display the symbol '?' at the end of LCD line. Change the speed you require.



- Press key  to store the new value. There will be the symbol '*' instead the symbol '?'.
- Your new setting is now stored.

5.3 Set the direction of rotation (Forward/Reverse function)



- Press  to set the direction of rotation (**Forward/Reverse**). Each key pressing will toggle the direction. In reverse mode the LCD will be:

LCD View

Comments

Set 500rpm=#2D	S Reference speed and number
Ready to run <<	R << - reverse direction

5.4 The Speed Control Loop. The PI Speed Control coefficients setting

The control system of the DVR Drive has Speed Control Loop which provides the PI speed controller function. The K_{Pror} and K_{Int} are the values of the Proportional and Integral coefficient of speed control loop. They are functions of motor speed. See Appendix A for the basic curves of the PI speed controller coefficients. There are three possible choices – Normal (default), Soft and Hard coefficient curves. The values K_{prop} & K_{int} are multiplied by 100 (given as a percentage).

- Press  ("Page") to go to next display page in order to select the coefficient curves:

LCD View	Comments
-----------------	-----------------

SPEED CONTROL <E> NORMAL	E Normal coefficient curves selected
---	--------------------------------------

- Press  to toggle changing the other coefficient curves:

LCD View	Comments
-----------------	-----------------

SPEED CONTROL <E> SOFT	E Soft coefficient curves selected
---	------------------------------------

LCD View	Comments
-----------------	-----------------

SPEED CONTROL <E> HARD	E Hard coefficient curves selected
---	------------------------------------

- Press  ("Page") again to see the PI coefficients:

LCD View	Comments
-----------------	-----------------
- | | |
|-------------------------|--|
| $K_{prop} = 250 \% *$ | S Proportional coefficient value (in percent) for selected speed |
| $K_{int} = 2000 \% / s$ | S Integral coefficient value (in percent/sec) for selected speed |

Note: The LCD shows the values of the Proportional and Integral coefficient of speed control loop for selected speed. The parameters K_{prop} & K_{int} get their values from the curves and calculations.

- Use the **Set Function** (see 4.1) in order to increase/decrease the coefficient values to adjust the coefficients for your type of load.

- Press , hold it and press  or  in order to move the symbol "*" at the display line end up and down in order to select the display line which is ready to edit.

Note: If you will change one of these values, it will be fixed and will not automatically change as the speed is adjusted. It will also over-ride load inertia until software hard reset.

- Use the Hard Reset Function in order to return the factory curves of these parameters.

5.5 Serial Number view.



- Press (‘‘Page’’) again to see Board Serial Number:

LCD View

Comments

SERIAL NUMBER 04067648

The Control Board Serial Number



Press (‘‘Main’’) to go to Main display page from any other display pages.

Maintaining the Nova DVR3000

General Maintenance

Always isolate from power supply (unplug) before carrying out any maintenance

<i>Interval</i>	<i>Maintenance</i>
After each use	Clean the work area and Lathe. Vacuum shavings and dust from the Headstock, Tailstock, under the Toolslide and in between the bed.
Monthly	Wax exposed cast iron parts with a good quality paste wax, especially the bed rails. Buff out the wax thoroughly. Check tightness of nuts and bolts. Lubricate, with one or two drops of light-weight oil, the tailstock quill threads, index pin shaft, and the toolslide camshaft (remove plastic plugs) and toolslide front camshaft bore.
6 Months	Grease tailstock quill threads. Turn the handwheel so the quill threads are exposed, apply grease to the threads, crank the handwheel back and forth to work in the grease, wipe off any excess. Lubricate the tailstock slot with one or two drops of light-weight oil. With the power switched off and dis-connected, remove the upper-rear guard and remove any wood dust with a vacuum cleaner. Avoid getting the nozzle too close to the electronics. After this step dust may fall into the Headstock so suck the dust out through the vent at the front of the Headstock under the spindle. Replace guard.

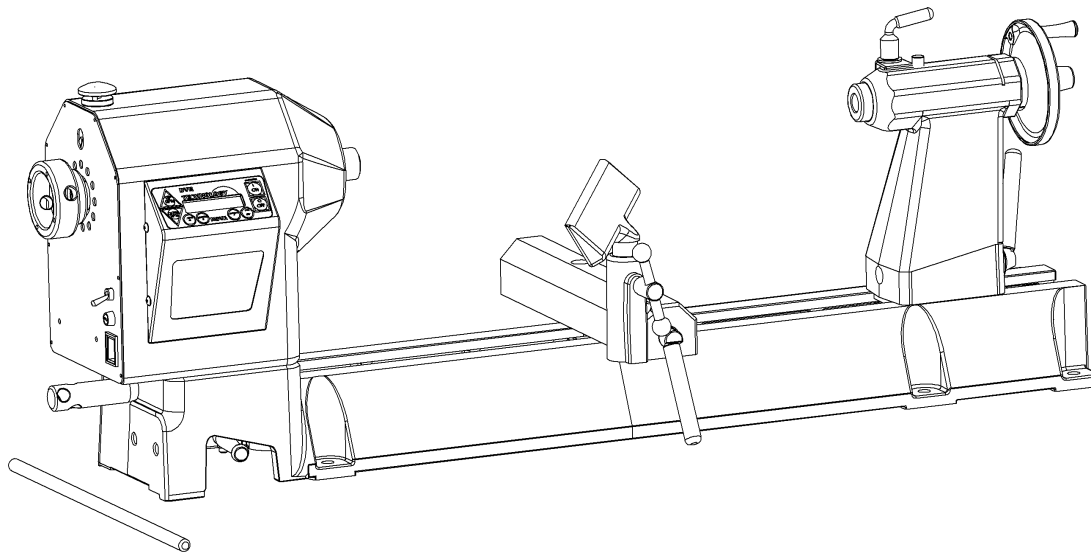

Cleaning the Toolslide

If the toolslide becomes hard to move and adjust, cleaning and lubricating are required.

1. To make the toolslide slide more freely along the bed, make sure the bed rails are clean. Apply some paste wax to the rails.
2. If the toolslide is hard to move towards or away from you, remove the toolslide from the lathe bed. Clean the toolslide camshaft (round eccentric rod) with a petroleum-based solvent. Lubricate the rod with lightweight oil or a silicone spray.
3. Slide the base back onto the lathe bed.

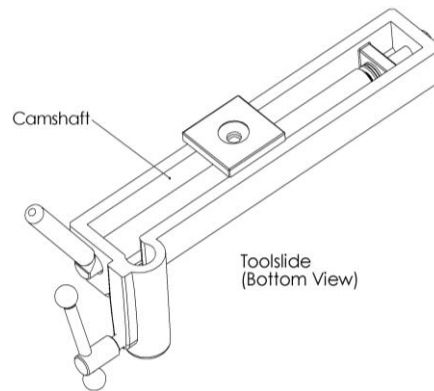

Cleaning the Tailstock

If the tailstock quill becomes hard to use or the Handwheel is hard to turn, cleaning and lubricating are required.

1. Remove the 6mm set screw from the tailstock. If necessary, turn the Handwheel to expose the set screw.
2. Using a screwdriver, remove the keeper plate from the tailstock body.
3. Remove the quill and Handwheel from the tailstock body.
4. Wipe clean all parts including the inside of the tailstock.
5. Lubricate the quill and tailstock slot with lightweight oil and apply a small amount of grease to the quill threads.
6. Reassemble.

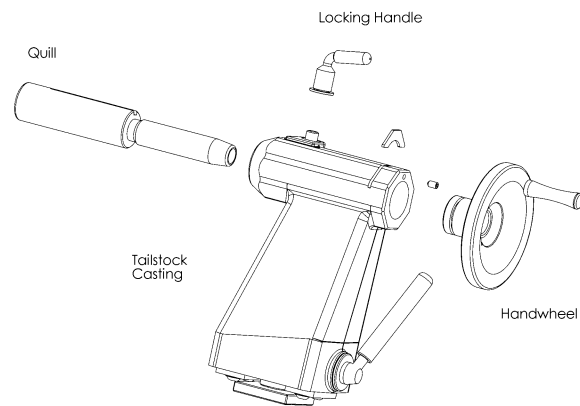

Aligning the Tailstock

1. Crank the Handwheel back so the quill is all the way in.
2. Place any #2 MT accessories you have that have a sharp point like a spur center, or live center in the tailstock quill and another center in the headstock spindle.

① Note: Tailstock alignment can be made easier by using the Teknatool AcruLine Accessory Center in place of the centers.

3. Move the tailstock close to the headstock so the two centers nearly touch; check the alignment of the center points. Move the tailstock away from the headstock and extend and lock the quill. The points of the centers should align when the quill is halfway extended, fully extended, and fully retracted.

If the centers are aligned at all three locations no adjustment is necessary.

4. If the tailstock does not meet the conditions in step 3, follow the steps below. This indicates that the tailstock is not parallel to the lathe bed and you will need to realign the tailstock.
5. First make sure the tailstock alignment plate is not binding inside the bed. If the tailstock doesn't move freely then remove the tailstock and look for burrs or high spots on the bed rails or the alignment plate. Using a smooth file remove any burrs or high spots. When done replace the tailstock on the bed.
6. Slightly loosen the four tailstock cap screws with a 5mm Allen wrench. Tap the tailstock with a wooden mallet in the appropriate direction to align the centers. Check and adjust the positioning of the tailstock. The centers should align when the quill is halfway extended, fully extended, and fully retracted, as previously described in step 3.
7. Lock the tailstock in place with the Tailstock Clamp Handle and fully tighten the two cap screws. The cap screws must be fully tightened in order to avoid slippage during work.
8. Check the alignment of the Tailstock by bringing it together with the Headstock, with the Live center and Spur center in each spindle. The Points on the centers should be within 0.50mm (0.020") height and width of each other

Voltage selection

By removing a small jumper the unit will efficiently run on 220V and a gain in power can be achieved. Or the jumper can be replaced to enable the unit to run on 115V.

1. Ensure that the power is off and that the plug is disconnected from the wall.



2. Allow minimum of 3 minutes discharging time for capacitors before opening rear panel.



3. Remove the rear lower switch panel. This will expose the main control panel in the lower compartment.
4. Use a pair of long nose pliers and earth yourself first by momentarily placing a hand on the lathe casting. This will remove any static electricity that could damage sensitive components. Visually locate the jumper. It will be between the 2 square blue capacitors.

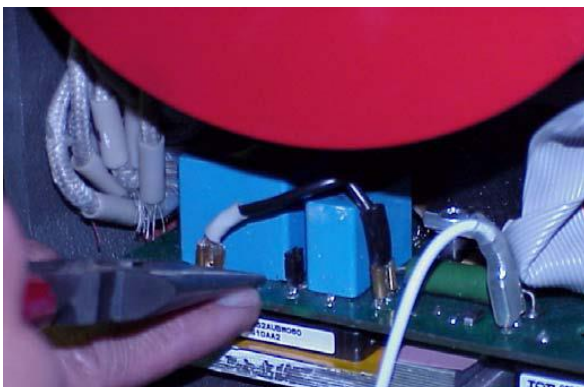

5. Carefully place your index finger on the edge of the board avoiding any solder points. Using the top of your finger as a guide run the pliers along and lightly grab the jumper in the pliers. Do not squeeze too tight as you may crush the jumper. This is important as the jumper will need to be placed back should you want to run 115V again.

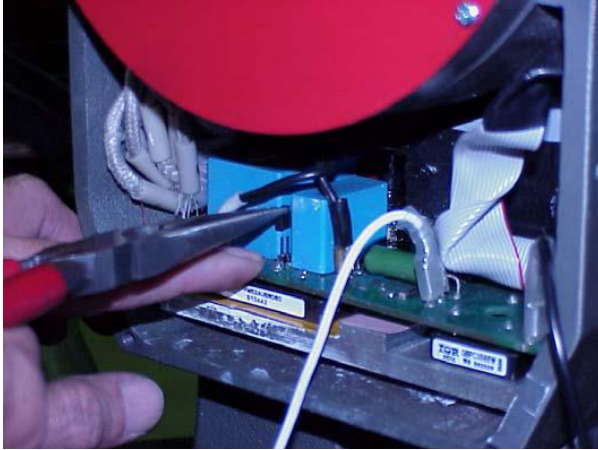

6. Reattach rear guard ensuring all wiring is captured inside casing. Be careful as the back of the fuse and switch protrude out and should not hit any components as you position the guard in place.
7. Securely fasten the guard with the 4 cap screws
8. Change the plug to a suitable 220V type either for 15 or 20 amp plug fitting.

Note: Your 220V power supply may be such that the voltage is split 110 V down each the phase and neutral. If so, then the neutral supply should be switched also, which requires the switch to be replaced with a double pole, single throw switch (DPST).

If the unit is plugged into a 115 volt outlet with the jumper now set to 220v , it will not damage the electronics and the motor will still run , but it will not have the same performance , and may show error – “current overload” under higher loadings.

9. The unit can now run 220V ~ 240V.

Troubleshooting Guide

<i>Problem</i>	<i>Possible Cause and Solution</i>
<i>Excessive vibration.</i>	<p>Out of balance, or large work piece. Reduce lathe speed to the lowest speed possible and turn the work piece to a true circle. Adjusting the speed using the up / down keys will change the speed in 10 rpm increments. If you try adjusting the speed up or down you will find that it is easy to find speed points that will minimize vibration and is one of the biggest advantages of DVR technology.</p> <p>Work piece is not held in the center. Check work piece mounting and correct.</p> <p>Work piece is not secure or held tight enough. Check work piece mounting.</p> <p>Lathe incorrectly bolted to stand or bench. Refer to this manual for lathe stand recommendations.</p> <p>Stand or bench not well constructed, too light, or not level on the floor. Make sure the stand is solidly constructed. Use sandbags to weigh down the stand.</p> <p>The metal floor stand should be Rawl bolted to the floor at the 4 hole points.</p>
<i>Faceplate or chuck running out of true.</i>	<p>Dirt build-up on the rear of the faceplates or chuck. Clean off all build-up and dirt. Faceplates and chucks must mount securely against the inner bearing ring surface of the spindle.</p>
<i>Turning tools not sliding smoothly across Toolrest.</i>	<p>Damaged surface on toolrest face caused by sharp edged tools. File the toolrest using a fine smooth file and polish with extra fine sandpaper. Also remove the sharp edges from the corners of turning tools.</p>
<i>Spur drive center or live center not holding into the spindle taper or quill taper when turning.</i>	<p>Small end of Morse taper is damaged due to dropping or hitting. File or polish away any damage. Check that inside of tapers have not been scored.</p> <p>Grease or oil inside of Morse tapers. Wipe clean the inside of the tapers.</p> <p>Insufficient pressure when installing the center. Use a quick, firm action by hand to install a taper. Do not knock in using any solid object.</p>
<i>Display screen not on</i>	<p>Is master switch on? Toggle master switch to "ON" position.</p> <p>Check machine is plugged into wall socket and switched on.</p> <p>Check that the wall switch plug is live by plugging in another power tool if the other power tool doesn't go check your board fuse.</p> <p>Check the master fuse on the lower rear guard. Ensure machine unplugged (see Additional safety rules at the front of this manual). If blown, replace with the spare fuse that comes with the lathe. Do not replace with a higher amp fuse.</p>

Display screen shows

**Rotor Fault
<Flashing>**

Press off button; switch off computer by master switch wait one minute and switch on again. Check that the spindle index is not engaged or that something is preventing the spindle from turning. Note leaving the spindle index unit in will not harm the motor, however it will put some strain on the index unit. It is likely that the spindle index will be left in from time to time and the motor is designed for this.

**RP State Error
<Flashing>**

The optical sensors that give the spindle position feedback ('Rotor Position' State) are obscured, damaged or have been disconnected. Dust over a long period of time may have settled on the sensors. Firstly spin the spindle by hand to create a draught through the sensors. Re-try the motor. If the error remains, with the power switched off and disconnected, remove the upper-rear guard and remove any wood dust with a vacuum cleaner. Avoid getting the nozzle too close to the electronics. After this step dust may fall into the Headstock so suck the dust out through the vent at the front of the Headstock under the spindle. Do this sequence a few times. Try blowing if available with Vacuum or Air gun. Replace guard.

LCD screen shows

**PFC Corrector
<Flashing>**

The computer has built in voltage condition and temperature sensors, if this message appears, check the temperature of the lower section of the headstock. If it is very hot, switch off the master switch and leave the machine to cool down for a period. If the headstock is relatively cool the computer may have detected an under and over voltage from the mains power. Switch off and try rebooting. The DVR has a high level of protection and is intelligently checking conditions all the time.

i *Note: Can't find the answer in this Trouble Shooting guide?*

Visit the Lathe Support Section on our website - this is packed with Frequently Asked Questions.

Or

Contact Us (details are at the front of this manual)

Troubleshooting Guide continued

<i>Problem</i>	<i>Possible Cause and Solution</i>
<i>Tailstock and headstock center not lining up correctly.</i>	<p>Bed incorrectly bolted to stand causing twist. Ensure stand and lathe are correctly installed.</p> <p>Headstock not returned to detent position after it has been rotated. Ensure that the headstock is locked into a detent position.</p> <p>Headstock Lockpin not fully seated. Twist the headstock back and forth to make sure it is properly seated and then tighten the Lockpin.</p> <p>Dirt or wood dust accumulated in the headstock swivel pin hole. Remove the Headstock Lockpin and clean out hole.</p>
<i>Tailstock Handwheel hard to turn or will not turn.</i>	<p>Quill lock is locked; unlock the quill lock. If necessary, lightly tap a block of wood against the handwheel handle; tap the handle in a clockwise direction as viewed from the tailstock end.</p> <p>Build up of dust and wood resin on the quill or inside of the handwheel thread. Remove, clean, and lubricate the quill and tailstock as described under "Cleaning the Tailstock".</p> <p>The quill has been extended too far and is locked against the handwheel. Push the quill back into the tailstock when turning the handwheel.</p>
<i>Tailstock quill hard to move.</i>	<p>Quill lock is locked; unlock the quill lock.</p> <p>The quill is damaged; turn the handle to expose the quill and check for marks along the quill, especially on the edges of the slotted keyway. Remove the high spots with a smooth file and test the quill travel. Replace the quill if necessary.</p>
<i>Tailstock not locking correctly onto bed, or tailstock not sliding smoothly on bed ways.</i>	<p>Tailstock adjustment plate not adjusted correctly; adjust as described under "Aligning the Tailstock".</p> <p>Dirty bed ways and underside of tailstock body. Clean bed ways and underside of tailstock body with a petroleum-based solvent.</p>
<i>Tailstock binds.</i>	<p>The inside of the bed has a high spot. File the area with a smooth flat file until the tailstock moves freely.</p> <p>The tailstock adjustment plate has a rough spot or a burr. Remove the tailstock and file the plate with a smooth flat file.</p>
<i>Tailstock jumps where bed sections join.</i>	<p>The machined flat surfaces are not flush. File the area with a smooth flat file until the tailstock moves freely.</p>

DVR XP Woodlathe Parts List

Item #	Qty	Part #	Description
1	1	55048	Lock Pin
2	1	24118	Main bed (Machined)
3	1	24023	Detent Pin
4	1	24060	Detent Spring
5	1	55176	Detent Lever
6	1	NHZ8	M8 nut
7	4	SW12	Spring Washer M12
8	4	FW12	Flat Washer M12
9	4	24011	Cap Screw M12 X 30
10	1	24119	Bed Extension
11	1	55029	Lever-Quill Locking
12	1	FW12	Flat Washer ZP M12
13	1	55037	Dowel Pin D12 X 30
14	1	55026	Shaft-Quill Lock
15	1	24040	Keeper Plate
16	1	25028	Adjustable Tailstock
17	1	G0610	M6X10 Grub screw-Tailstock
18	1	55028	Quill-Tailstock 1.5" Dia
19	1	55153	Lock arm- Tailstock
20	1	TP0820	Tension Pin 8X20
21	1	24065	Handle-Handwheel
22	1	24043	Handwheel Casting
23	1	55027	Sleeve-camshaft
24	1	55025	Camshaft-Tailstock
25	1	24048	Camnut-Tailstock
26	2	25029	Alignment Plate
27	4	FW8	Flat Washer M8
28	4	BHC0816	Capscrew Button Head M8
29	1	27002	Lock plate-Tailstock
30	1	K1225	M12X25 Countersunk screw-Tailstock
31	1	24120	Toolrest
32	2	865913	Knob Ball
33	1	25001	Tee lock arm
34	1	24026	Tee lock body
35	1	55153	Lock arm- Toolslide
36	1	24020	Camshft-Toolslide
37	1	G0610	M6X10 Grub screw-Tailstock
38	1	K1225	M12X25 Countersunk screw-Toolslide
39	1	27002	Lock plate-Toolslide
40	1	FW12	Flat Washer M12 ZP 1.6MM Thick
41	1	BNMZ12090	Bolt ENG M12X 90 ZP
42	1	24048	Camnut-Toolslide
43	1	24009	Tooslide
44	1	HP-16	Hole Plug
45	1	55036	Index Knob
46	1	TPI31658	3/16" 5/8" Tension Pin
47	1	55033	Index Pin Face
48	1	55035	Index Guide Bush
49	2	6207RS1-C0	Trimax Bearings-Front

USE 55151

Item #	Qty	Part #	Description
50	1	55012	Swivel Pin-Headstock
51	1	55145	Headstock
52	4	M5	M5x10 screw
53	1	55040	Backing Plate
54	1	55019	Interface Board
55	1	55014	Front Control Cover
56	1	55010	Keypad Membrane
57	1	55049	LCD Interface Board
58	4	M3 CSK Screw	M3x10 Countersunk Screw
59	1	55003	Headstock Spindle 1 1/4" 8 UNS RH
	1	55103	Headstock Spindle M33 X 3.5 RH
60	1	55007	Rotor Lamination Set
61	1	55005	Spacer Ring
62	1	55050	Rotor Key
63	1	55009	Stator
64	1	55146	Bearing Carrier
65	1	55004	Position Disc
66	1	55006	Encoder Ring
67	1	6207RS1-C0	Trimax Bearings-Rear
68	1	EC35	Circlip-Rear Bearing
69	1	55051	Fan Key
70	1	G0606	M6X6 Grub Screw-Fan
71	1	55011	Fan/Index Plate
72	1	55174	Sensor Guard
73	1	55100-55130	EMI Filter
74	1	55018	Control Board (Version Vary)
75	1	55212	Heatsink Aluminium
76	8	MP05010	Pan Pozi Screw
77	1	55124	IEC SNAP Inlet
78	1	LHB	Handbrake handwheel
79	1	55152	Switch Toggle Chilly
80	1	55061	Holder Fuse Safety
81	1	55172	Endcover EMI DVR
82	1	55081	Operating Bar

Nova DVRXP Lathe

index assy
55151

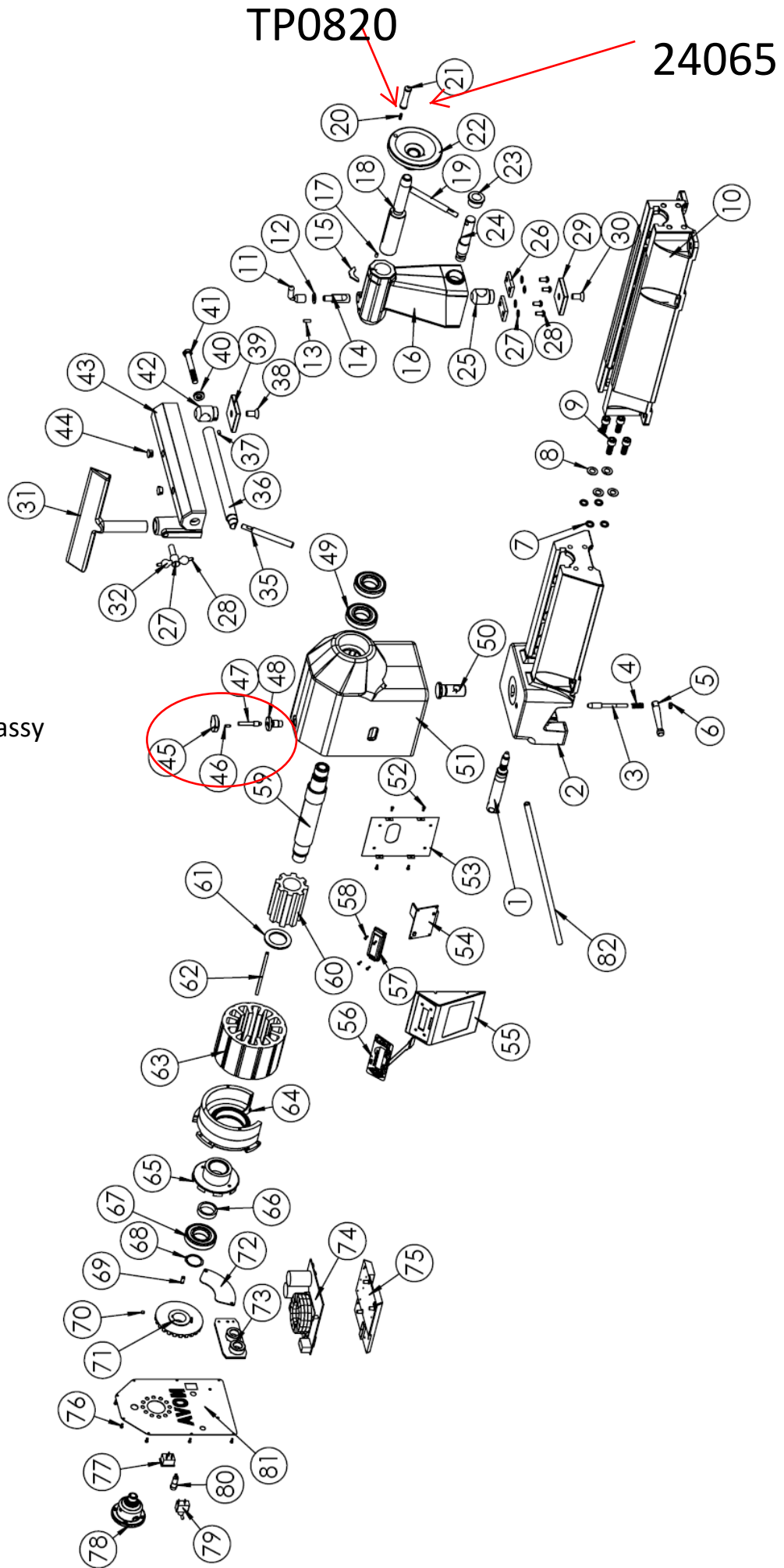

Accessories

Add On Bed Extension: 55195

Extend the bed of your Nova DVR XP Woodlathe for greater capacity for turning between centers. Each bed unit adds 510mm (20in.)

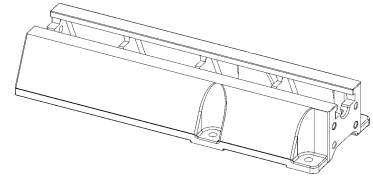

Lathe Stand

The stand pieces are cast from a high grade of Cast iron with extremely good section thickness and CAD generated internal gussets at all critical points to withstand extremely high stresses with practically no distortion. Cast iron has always been the material of choice for wood lathe construction because of its inherent mass and excellent modulus of vibration dampening. The cast iron stand has been purposely designed to be heavy, solid and robust keeping this in mind.

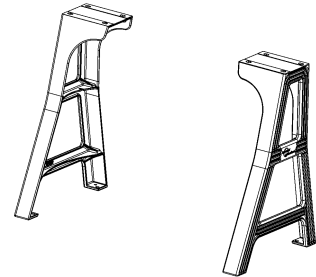

“New” Hybrid Stand

The hybrid stand is a combination of cast iron and rectangular hollow section. Compared to its original predecessor, the hybrid was designed to be light weight and style.

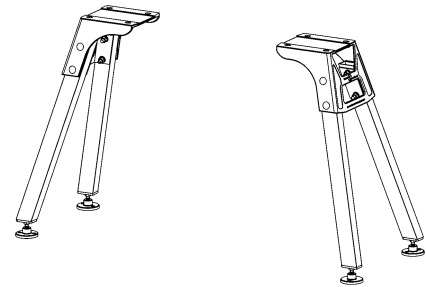

Small Toolrest: TR100/1

A small 100mm (4in.) toolrest (not shown) for turning small work pieces or reaching into recessed areas.

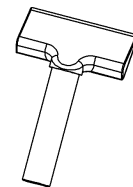

Bowl Toolrest:

A curved toolrest, which gives you better chisel support on both the outside and inside of a bowl. Because of the curve you are able to position your chisel support closer to the bowl.

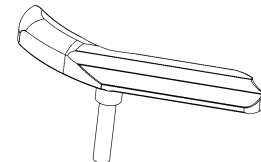

Revolving Center System: NLCS or NLCS1

A multi-function live center system to expand your options when turning between centers. It includes quick change tapers: a hollow cup center point, threaded center, cone center, and an extension center. Made with three bearings and precision machined for a high quality finish.

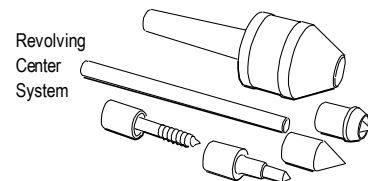

Handwheel Unit: LHB

The handwheel is mounted on the outboard end of the headstock spindle so you can manually position work or to slow it down. The vacuum coupler can also be added to this unit to make a vacuum holding option.

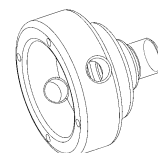

Accessories

Faceplates:

SFP80L (with side-locking function).

Faceplates are used to mount the work piece when faceplate turning bowls or platters. Faceplates are available in 80mm (3") diameter. A vacuum faceplate is also available. The 80mm (3") faceplate is made of solid steel. This faceplate has a small contact area to allow maximum freedom while shaping. It comes with 2 notches on the outside diameter for removing the faceplate from the spindle. This can be done with a light drift and mallet.

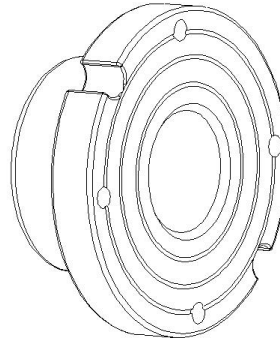

Vacuum Coupler: 25008

The Vacuum Coupler (not shown) fits onto the Handwheel Unit. It provides a secure attachment for your vacuum cleaner hose. For those turners who are interested in vacuum chucking, this is a simple system.

Outrigger Unit: OR3000

Extend the bowl turning capacity of the Nova DVR XP Woodlathe to up to 740mm (29in.) in diameter. This unit is made from cast iron, is easy to position and control, and mounts to the headstock end of the lathe.

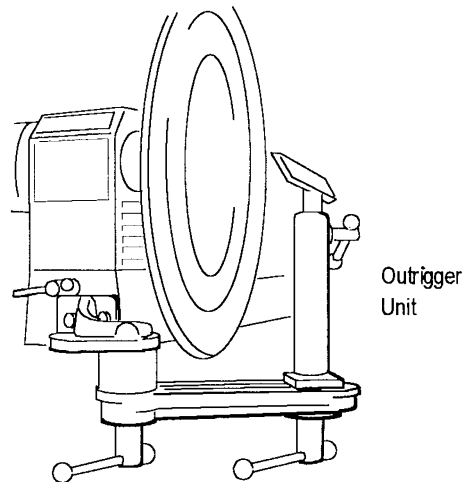

Precision Midi Chuck

Ideal for mini, midi and all lathes up to 6" centre height (12" diameter over bed) Can also be used for small work on large lathes.

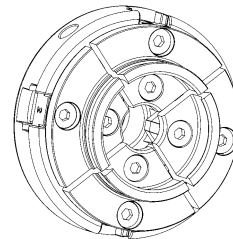

Supernova 2 Chuck

Designed for the tough demands of modern woodturning. Body is precision machined from high quality K1045 machine steel. Gearing is heavy section, hardened steel to provide a powerful action. The greater holding strength, stability, and precision decreases vibration from small delicate turnings right up to large bowls and platters work (up to 29"/740mm)

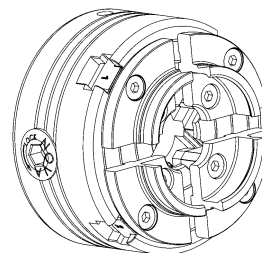

For further details about Teknatool's lathe accessories please contact your local retailer for more information, or contact us for a free product catalogue. This catalogue can also be downloaded from our website - at www.teknatool.com

Index

- Accessories 42,43
- Assembling 11
- Bed - Lathe 2, 3, 9, 13, 14, 21, 22, 23, 33, 35,37,42,43

- Camshaft 33,38
- Centerlines Turning 8, 20
- Centers 8, 9, 13, 20, 21, 22, 33, 42
- Changing Speeds 15,16
- Cleaning 32,33
- Components 3, 8, 12
- Connecting to Power, 14
- Contents, 5
- Distance between Centers, 9
- Electrical 3, 7, 8, 10, 14
- Extension Bed, 13, 37
- Extension Cords, 10, 14
- Faceplate, 2, 8, 9, 20, 35,43
- Function, 3, 7, 16, 17, 20, 42, 43
- Handles, 8, 12, 13, 19, 21, 22, 33
- Handwheel, 9, 22, 33, 37,42
- Headstock Lockpin, 12, 19, 37
- Headstock, 2, 3, 8, 9, 10, 12, 14, 19, 20, 21, 32, 35, 37
- Lathe Stand Requirements, 10, 35
- Live Center, 9, 33, 35, 42
- Maintenance, 2, 6, 32
- Mounting Faceplate or Chuck, 8, 20, 35
- Mounting, Lathe, 2, 13, 14, 35
- Nova DVR3000 Specifications, 9
- Oil, 32, 33, 35
- Operating, 7, 8, 19
- Operating Bar, 12, 19, 22

- Outrigger Unit 9, 14, 43
- Parts List 38, 39
- Power, 2, 3, 7, 8, 10, 14, 15, 16, 17, 18, 32,35

- Problems 35, 37
- Quill, 8, 9, 22, 32,33,35
- Removing Centers and Tapers, 22
- Revolving Center System, 42
- Rpm, 3, 9, 15, 16, 17, 18, 35
- Safety, 6, 7
- Sanding, 8, 10, 11, 18, 21, 35
- Shop Requirements, 10
- Speed, 2, 3, 8, 9, 15, 16, 17, 18, 22, 35
- Spindle Index, 2, 9, 16, 19, 20, 32
- Spindle Threads,2, 9, 20
- Spur Center, 8, 9, 21, 35
- Stand, 2, 10, 11, 14, 26, 37, 42
- Standard Equipment, 8
- Swing, 8
- Swiveling the Headstock, 12, 19

- Tailstock parts list, 38, 39,41
- Tailstock, 2, 8, 9, 12, 13, 14, 22, 33
- Teknatool, 4, 5, 6, 20, 33,42
- Toolrest, 9, 13, 16, 21, 26, 33
- Toolslide Parts List, 38,39
- Troubleshooting, 35, 37
- Turning between Centers, 20
- Turning Speeds, 21
- Turning, 2, 3, 4, 8, 9, 10, 14, 18, 19, 20, 21, 22, 32, 35, 42,43

- Unpacking, 12
- Vacuum Coupler, 9, 43
- Vibration, 3, 10, 11, 18, 35

- Warranty, 45
- Website, 4

Teknatool Warranty

Teknatool Five Year Limited Warranty (2 year on electrical parts)

This Teknatool product is backed by a warranty from the date of purchase. Teknatool International Ltd will repair or replace, at its expense and option, this Teknatool product which in normal use has proven to be defective in workmanship or material, provided that the customer returns the product prepaid to an authorized Teknatool service center with proof of purchase of the product within TWO YEARS and provides Teknatool with reasonable opportunity to verify the alleged defect by inspection. Teknatool will pay return product by most cost effective surface transport to customer. Any special freight services above this will be at customer cost. Furthermore, Teknatool International Ltd. extends this two-year period for three additional years, excluding labor costs and electrical parts, provided the aforementioned conditions are met. All electrical parts and electronics are covered by a TWO YEAR warranty from the date of purchase.

Teknatool will not be responsible for any asserted defect, which has resulted from normal wear, misuse, abuse, Power surges or excess voltage fluctuation, repair or alteration made by anyone other than an authorized service facility or representative. Under no circumstances will Teknatool International Ltd. be liable for incidental, special, indirect, and consequential damages or expenses, including loss of profits or loss of operations. This warranty is Teknatool International Ltd sole warranty. There are no other warranties, whether written or verbal, whether expressed or implied by law, trade, custom, or otherwise, whether of merchantability, fitness for purpose, or otherwise, except for remedies available to customers under the Consumer Guarantees Act or other legislation.

OVERSEAS CUSTOMERS: Our Teknatool Distributors and agents will issue their own warranty to cover this product. Terms may vary from those stated above; please check with your dealer. In North America warranty covers Continental USA only. For Alaska, Hawaii and other areas, warranty covers replacement of parts only and excludes transport costs.

i Note: Did you know you can register your warranty with Teknatool online? Visit our website on www.teknatool.com to register your warranty faster today! Or you can fill out the card below, cut, fold, seal and post.



Teknatool Warranty Card

Return this card to validate your warranty, or register online at www.teknatool.com.

Name: _____

Address: _____

Email Address: _____

Phone: _____

Teknatool Product Model _____

Serial Number (at the front of headstock) _____

Date of Purchase _____

Reseller _____

Would you like to be on our mailing list and receive complimentary copies of our Teknatool Newsletter? (Personal information is kept confidential.)

Yes, by email No

To help us provide services and products that are better tailored to your needs, please answer the following:

- Where did you purchase the product? (check one)
 Local Woodturning Specialty Manufacturer
 Local General Woodworking Mail-order Catalog
 Other (specify) _____
 - Did you receive all information you required and expected?
 Yes No
If no, explain: _____
 - What other products did you buy along with lathe purchase?
 Lathe Chuck Finishes Power Tools
 Lathe Chisels Abrasives Other Products
 Lathe Accessories (list) _____
 - Why did you buy the Nova Lathe?
 Features Quality Warranty Store Advice
 Price NZ Made Accessories Product Support
 Recommended Reputation of Brand
 - Rate your woodturning and woodworking experience:
 Beginner Intermediate Advanced
- Comments _____

i Note: To locate the serial number, look to the front of the headstock, under the control panel. The serial number is printed on the safety label sticker.

Steps to registering your Warranty by Mail:

1. Fill out the information on page 36, duplicate your serial number here for your future reference:

Serial Number: _____

- 2. Cut along the dotted line as indicated by the scissors icon.
- 3. Take the cut out, and fold along dotted line as shown.
- 4. Seal edges with sellotape/glue/tape etc.
- 5. Affix appropriate Postage Stamps for postage to New Zealand and post.
- 6. *Optional:* List your return address details in the event of mishandled post.



Affix
Postage

Fold
Here

Seal Along Edge

Post To:

TEKNATOOL INTERNATIONAL

Warranty Registration

PO Box 305378 Triton Plaza

North Shore 0757

Auckland

NEW ZEALAND

Fold
Here

Return Address:

Seal Along Edge



Nova DVR XP Woodlathe Manual

Publication Code: 115-0214-004

© Teknatool International 2000-2014

