

INSTRUCTION MANUAL

Nova 3000TM
Woodlathe



Part No. 92-9901-013

Thank you for choosing our Nova 3000 Woodlathe and welcome to the Teknatool product family. Your choice shows you want the best for your woodturning and recognise the superior and unique features the Nova 3000 lathe offers.

We strive to achieve the best value for your money - providing quality where it counts, innovative features, a wide variety of accessories (some of them unique to Teknatool) - plus comprehensive, ongoing support (latest manuals downloadable from our website, free newsletters, projects etc). We are only a phone call or email away with technical advice or assistance on the operation of your lathe or your woodturning queries.

Please feel free to contact us about any aspect of our products or service - we regard our customers as our best development and improvement team - we'd love to hear from you!

Once again, welcome to the "Teknatool Family". We hope you enjoy our products and hope they enhance the pleasure you experience from the wonderful craft of woodturning!

Best Regards



Brian Latimer
Marketing Director
Teknatool International Ltd.

Teknatool International Ltd.

P.O. Box 18-0034
Luckens Point
Henderson, Auckland 1008
New Zealand

Phone: (0064) 9 837 6900
Fax: (0064) 9 837 6901
Email: service@teknatool.com
Website: www.teknatool.com

Be sure to visit our website www.teknatool.com to register your lathe on line, find out what's new, locate local turning clubs, download manual updates, projects and newsletters, or receive assistance.

Table of Contents

General Safety Rules	4
Additional Safety Rules for Woodlathes	5
Nova 3000 Specifications	6
Setting Up Your Workshop.....	7
Workshop Requirements	7
Lathe Stand Recommendations.....	7
Motor Recommendations.....	8
Assembling the Nova 3000.....	9
Adding an Extension Bed	12
Mounting the Lathe to a Support Surface	13
Connecting to Power	13
Using the Nova 3000	14
Parts of the Nova 3000 Woodlathe.....	14
Recommended Turning Speeds	14
Changing Speeds	15
Swiveling the Headstock.....	15
Spindle Index.....	16
Headstock	16
Toolrest	17
Tailstock	18
Learning Turning	18
Maintaining the Nova 3000.....	19
General Maintenance	19
Cleaning the Toolslide	19
Cleaning the Tailstock	20
Aligning the Tailstock.....	20
Troubleshooting Guide	21
Nova 3000 Woodlathe Parts List	23
Accessories.....	25
Index	27
Warranty	28

© Copyright 1999 by Teknatool International; All Rights Reserved. Nova 3000 is a registered trademark of Teknatool International and Latalex Ltd.

The information and specifications contained herein are subject to change. Teknatool is not responsible for errors or omissions herein or for incidental damages in connection with the furnishing or use of this information.

GENERAL SAFETY RULES



Warning! Failure to follow these rules may result in serious personal injury.

1. **FOR YOUR OWN SAFETY, READ THE MANUAL BEFORE OPERATING THE TOOL.** Learn the machine's application and limitations plus the specific hazards peculiar to it.
2. **ALWAYS USE SAFETY GLASSES.** Wear safety glasses (must comply with ANSI STANDARD Z87.1 -USA) Everyday eye-glasses usually are only impact resistant; they are not safety glasses. Also use face or dust mask if cutting operation is dusty.
3. **WEAR PROPER APPAREL.** Do not wear loose clothing, gloves, neckties, rings, bracelets or other jewelry which may get caught in moving parts. Non slip footwear is recommended. Wear protective hair covering to contain long hair.
4. **USE EAR PROTECTORS.** Use ear muffs for extended period of operation. Use muffs rated to 103 DBA LEQ (8 hour).
5. **DON'T USE IN DANGEROUS ENVIRONMENT.** Don't use power tools in damp or wet locations, or expose them to rain. Keep work area well lighted.
6. **KEEP WORK AREA CLEAN.** Cluttered areas and benches invite accidents. Build up of sawdust is a fire hazard.
7. **KEEP CHILDREN AND VISITORS AWAY.** All children and visitors should be kept a safe distance from work area.
8. **MAKE WORKSHOP CHILDPROOF** with locks, master switches, or by removing starter keys.
9. **GROUND ALL TOOLS.** If the tool is equipped with a three prong plug, it should be plugged into a three hole electrical receptacle. If an adapter is used to accommodate a two prong receptacle, the adapter lug must be attached to a known ground. Never remove the third prong.
10. **MAKE SURE TOOL IS DISCONNECTED FROM POWER SUPPLY** while the motor is being mounted, connected, or reconnected.
11. **DISCONNECT TOOLS** before servicing and when changing accessories such as blades, bits cutters, etc.
12. **AVOID ACCIDENTAL STARTING.** Make sure switch is in the Off position before plugging in power cord.
13. **NEVER LEAVE MACHINE RUNNING UNATTENDED.** Do not leave tool unless it is turned off and has come to a complete stop.
14. **KEEP GUARDS IN PLACE** and in working order.
15. **USE RIGHT TOOL.** Do not use a tool or attachment to do a job for which it was not designed.
16. **USE RECOMMENDED ACCESSORIES.** The use of improper accessories may cause hazards.
17. **DON'T FORCE TOOL.** It will do the job better and be safer at the rate for which it was designed.
18. **MAINTAIN TOOLS IN TOP CONDITION.** Keep tools sharp and clean for best and safest performance. Follow instructions for lubricating and changing accessories.
19. **NEVER STAND ON TOOL.** Serious injury could occur if the tool is tipped or if the cutting tool is accidentally contacted.
20. **REMOVE ADJUSTING KEYS AND WRENCHES.** Form habit of checking to see that keys and adjusting wrenches are removed from tool before turning it on.
21. **DON'T OVERREACH.** Keep proper footing and balance at all times.
22. **DIRECTION OF FEED.** Feed work into a blade or cutter against the direction of rotation of the blade or cutter only.
23. **ATTENTION TO WORK.** Concentrate on your work. If you become tired or frustrated, leave it for awhile and rest.
24. **SECURE WORK.** Use clamps or a vice to hold work when practical. It's safer than using your hand and frees both hands to operate tool.
25. **CHECK DAMAGED PARTS.** Before further use of the tool, any part that is damaged should be carefully checked to ensure that it will operate properly and perform its intended function. Check for alignment of moving parts, binding of moving parts, mounting, and any other conditions that may affect its operation. Any damaged part should be properly repaired or replaced.
26. **DRUGS, ALCOHOL, MEDICATION.** Do not operate tool while under the influence of drugs, alcohol, or any medication.
27. **DUST WARNING.** The dust generated by certain woods and wood products can be injurious to your health. Always operate machinery in well ventilated areas and provide for proper dust removal. Use wood dust collection systems whenever possible.

ADDITIONAL SAFETY RULES FOR WOODLATHES



Warning! Failure to follow these rules may result in serious personal injury.

1. **DO NOT MODIFY OR USE LATHE FOR USES OTHER THAN FOR WHICH IT WAS DESIGNED.**
2. **SEEK INSTRUCTION.** If you are not thoroughly familiar with the operation of woodlathes, obtain advice from your supervisor, instructor, or other qualified person. Instruction from a qualified person is strongly recommended.
3. **DO NOT OPERATE LATHE** until it is completely assembled and installed.
4. **FOLLOW ELECTRICAL CODES.** Make sure wiring codes and recommended electrical connections are followed and that the machine is properly grounded.
5. **KEEP WORK AREA CLEAN.** Do not turn the lathe On before clearing the lathe of all objects (tools, scraps of wood, etc.). Keep the nearby area and floor clear of debris.
6. **CHECK SET-UP** with power Off. Examine the set-up carefully and rotate the work piece by hand to check clearance before turning on power.
7. **DO NOT MAKE ADJUSTMENTS** when the lathe or work piece is turning. Make all adjustments with power Off.
8. **TIGHTEN ALL CLAMP HANDLES** on the headstock, tailstock, and toolrest before operating lathe.
9. **EXAMINE WORK PIECE** and glue joints before turning to make sure it has no defects that would cause it to break when turning.
10. **USE LOWEST SPEED** when turning a new or unbalanced work piece.
11. **TURN AT RECOMMENDED SPEED.** Always operate the lathe at the recommended speeds. Consult this manual for suggested speeds.
12. **ADJUST TOOLREST** close to the work piece. Before turning, revolve the stock by hand to make sure it clears the rest. At intervals, stop the lathe and readjust the toolrest.
13. **KEEP TOOL ON TOOLREST.** The lathe tool or chisel should be on the toolrest before the lathe is turned On. Tools should remain on the toolrest whenever the tool is engaged in contact with the work piece.
14. **REMOVE TOOLREST** when sanding or polishing so fingers do not get pinched.
15. **USE CORRECT LATHE TOOLS.** Do not use spindle turning chisels for faceplate mounted work, and vice versa. Spindle turning tools used for faceplate turning may grab the work piece and pull the chisel from your control.
16. **WHEN ROUGHING STOCK** do not jam the lathe tool or chisel into work piece or take too big a cut.
17. **DO NOT POUND WORK PIECE** into headstock drive (spur) center when turning between centers. Pound the drive center into the work piece with a soft mallet before installing it between centers in the lathe.
18. **DO NOT USE TAILSTOCK** to drive work piece into the drive (spur) center when turning between centers. Secure work between centers with light pressure from the tailstock quill action.
19. **FASTEN STOCK SECURELY BETWEEN CENTERS.** Make sure the tailstock is locked before turning on the power.
20. **NEVER LOOSEN TAILSTOCK** spindle or tailstock while work piece is turning.
21. **COORECTLY USE FACEPLATE.** When faceplate turning, make sure work piece is securely fastened to the faceplate and that appropriate size faceplate is used to support the work piece. Any screw fasteners must not interfere with the turning tool at the finished dimension of the work piece. Rough-cut the work piece as close as possible to finished shape before installing on faceplate.
22. **DO NOT OPERATE LATHE IF DAMAGED OR FAULTY.** If any part of your lathe is missing, damaged or broken, in any way, or any electrical component fails, shut off the lathe and disconnect the lathe from the power supply. Replace missing, damaged, or failed parts before resuming operation.
23. **ADDITIONAL SAFETY INFORMATION** regarding the safe and proper operation of this product is available from the National Safety Council, 444 N. Michigan Avenue, Chicago, IL 60611 in the Accident Prevention Manual of Industrial Operations and also in the Safety Data Sheets provided by the NSC. Also refer to the American National Standards Institute ANSI 01.1 Safety Requirements for Woodworking Machines and the U.S Department of Labor OSHA 1910.213 Regulation.

Nova 3000 Woodlathe Specifications

Size: see drawing below.

Weight: 66 kg (145 lb) (without motor)

Swing Over Bed: 400 mm (16 in.)

Distance Between Centers: 600 mm (24 in.); expandable in 510 mm (20 in.) units with add-on Bed sections.

Swing Outboard: 740 mm (29 in.) with headstock at 90° with outrigger toolrest.

Headstock:

Spindle Thread: M30 x 3.5 RH ⁽¹⁾ or 1-1/4 x 8 TPI RH ⁽²⁾

Headstock Bore: No. 2 Morse Taper (#2 MT)

Headstock Swivel: 0 to 360 degrees, with detents at 0, 22.5, 45, and 90 degrees.

Outboard End Internal Thread: M20 x 1.5 LH
Spindle Index: 24 divisions (every 15 degrees)

Tailstock:

Tailstock Bore: No. 2 Morse Taper (#2 MT)

Quill Travel: 85 mm (3-1/4 in.)

Hole Through Tailstock: 15 mm (9/16 in.)

Toolrest:

Length: 300 mm (12 in.)

Shaft Diameter: 25.4 mm (1 in.)

Motor Options (Recommended):

AC Motor, 1 HP, 1425 rpm, 50 Hz ⁽¹⁾

AC Motor, 1 HP, 1725 rpm, 60 Hz ⁽²⁾

DC Motor, 1 HP, 0-1750 rpm, 50-60 Hz

Speeds (rpm): 8-step motor pulley

178, 300, 570, 850, 1200, 1800, 2400, 3000 ⁽¹⁾
215, 360, 690, 1030, 1450, 2180, 2900, 3630 ⁽²⁾

Standard Equipment:

300 mm (12 in.) Toolrest, Poly Vee Drive Belt, Motor Pulley, Motor Mounting Kit, 150 mm (6 in.) Faceplate (not all countries), Spur Center, and Live Center

Nova 3000 Bowl Lathe Version:

Specifically for bowl turning, does not include bed extension, tailstock, and centers.

Optional Accessories:

Foot Mounting Rail Kit
Nova Chuck System
SuperNova Chuck System
Faceplates: 80 mm (3 in.), 150 mm (6 in.)
Vacuum Faceplate
Toolrest: 100 mm (4 in.)
Bowl Toolrest
Outrigger Toolrest Unit
Handwheel
Vacuum Coupler
Revolving Center System
Ornamental Turner
Hiturn Sharpening Center

Notes:

(1) Applicable to New Zealand, Australia, UK, Europe, and South Africa.

(2) Applicable to United States and Canada.

Allow clearance to pivot headstock and insert tools through the tailstock.

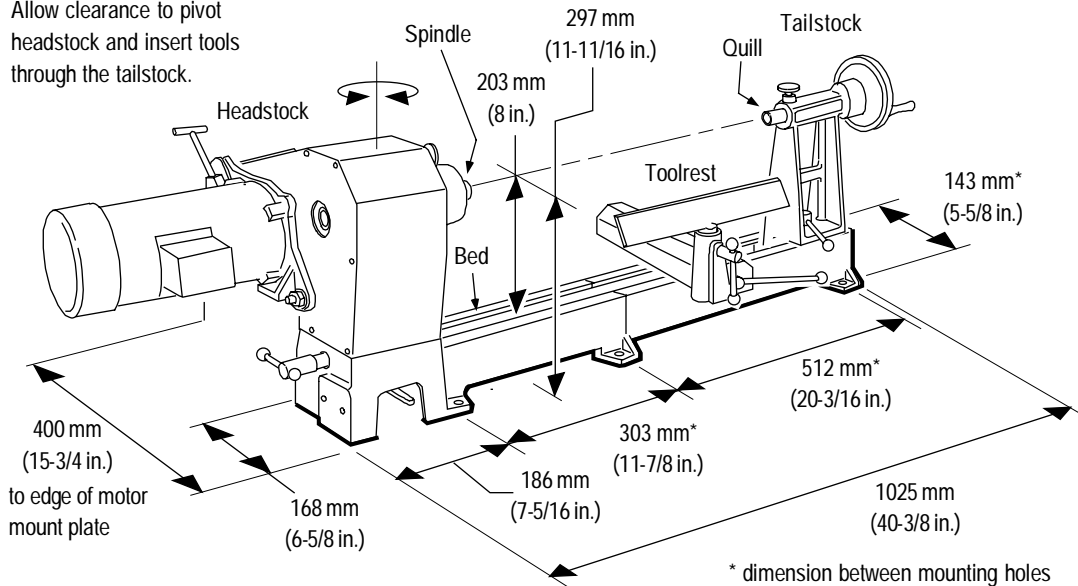

Setting Up Your Workshop

Workshop Requirements

<i>Consideration</i>	<i>Recommendation</i>
Lathe Location	Locate the Nova 3000 close to a power source in an area with good lighting. Leave clearance to all sides of the lathe; allow for motor clearance when the headstock is swiveled. Other machines in your shop should not interfere with the operation of the lathe.
Lighting	Your shop should have adequate lighting. The work area of the lathe should be well lit; there should not be shadows cast on your work. If possible, locate near a window. A movable spotlight may be helpful.
Electrical	The Nova 3000 requires the appropriate outlet nearby to power the motor. Wiring and outlets should follow local electrical codes. If in doubt, seek advice from an electrician. Minimize use of extension cords.
Ventilation	Your shop should be adequately ventilated. The degree of ventilation will vary based on the size of the shop and the amount of work done. The use of dust collectors and filters will minimize risks to your health.

Lathe Stand Recommendations

A sturdy and rigid stand is required so that the Nova 3000 Woodlathe can deliver optimum performance. A common flaw with many woodlathe installations is an inadequate stand for the lathe. The larger the size of your turnings, the greater the importance of the lathe stand design.

<i>Consideration</i>	<i>Recommendation</i>
Lathe Height from floor	The height of the stand should locate the centerline of the lathe spindle at the elbow height of the turner.
Stand Top	The stand top should be flat so the lathe does not twist when it is bolted down. Check for any gaps between lathe feet and stand top before bolting down. Shim and prepare stand as necessary.
Stand Weight	The stand should have enough weight and mass so it doesn't move when turning large work pieces, and so that the stand can absorb vibrations. A lathe stand's stability can be improved by weighing it down with sand bags on a lower shelf.
Stand Legs	The stand should sit level on the floor and not rock.

Example of Shop-made Lathe Stand

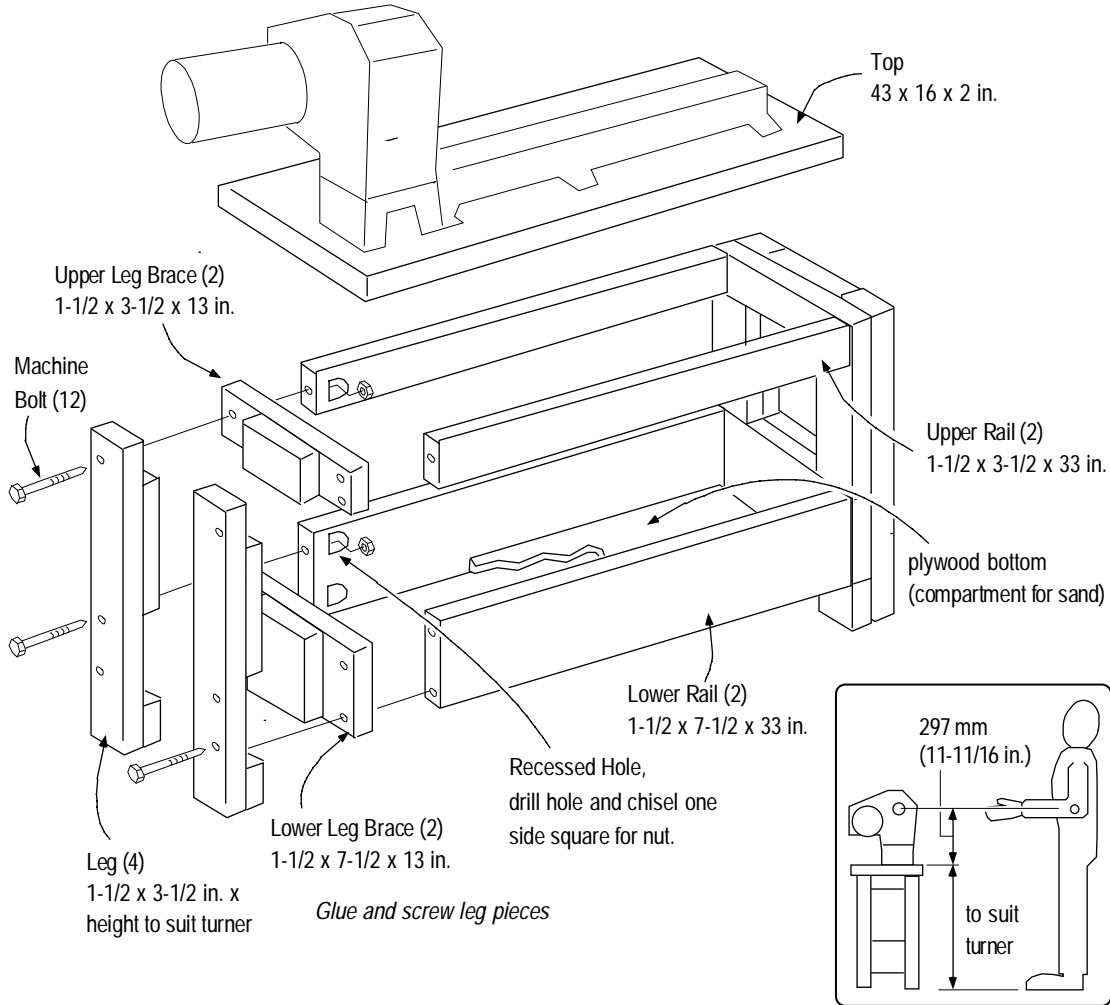

Motor Recommendations

The Nova 3000 can be purchased with or without a motor. If you are providing your own motor, adhere to the recommendations below. A variable speed DC motor may also be used; recommendations are similar to those for AC motors.

AC Motor Recommendations

Country	Motor Recommendations
United States, Canada	1 HP, totally enclosed fan cooled (TEFC), continuous duty, 1725 rpm, single phase, 60 Hz, with a keyed 5/8-inch shaft, and foot mounted NEMA 56 frame or flange frame.
New Zealand, Australia, UK, Europe, South Africa	1 HP, totally enclosed fan cooled (TEFC), continuous duty, 1425 rpm, single phase, 50 Hz, with a keyed 19 mm shaft, and foot mounted B56 frame or D80 Metric flange frame.

Note: The optional Foot Mounting Rail Kit is required for foot mounted motors.

Assembling the Nova 3000

1. Unpack the lathe and components from the shipping container.



Warning!

Have other people help when moving or lifting the Nova 3000 Woodlathe; it weighs about 66 kg (145 lb) without a motor.

2. Clean any parts coated with rust preventative with a cloth moistened with a petroleum-based solvent or cleanser, such as paint thinner. Coat the lathe bed with paste wax.

Nova 3000 Components After Unpacking

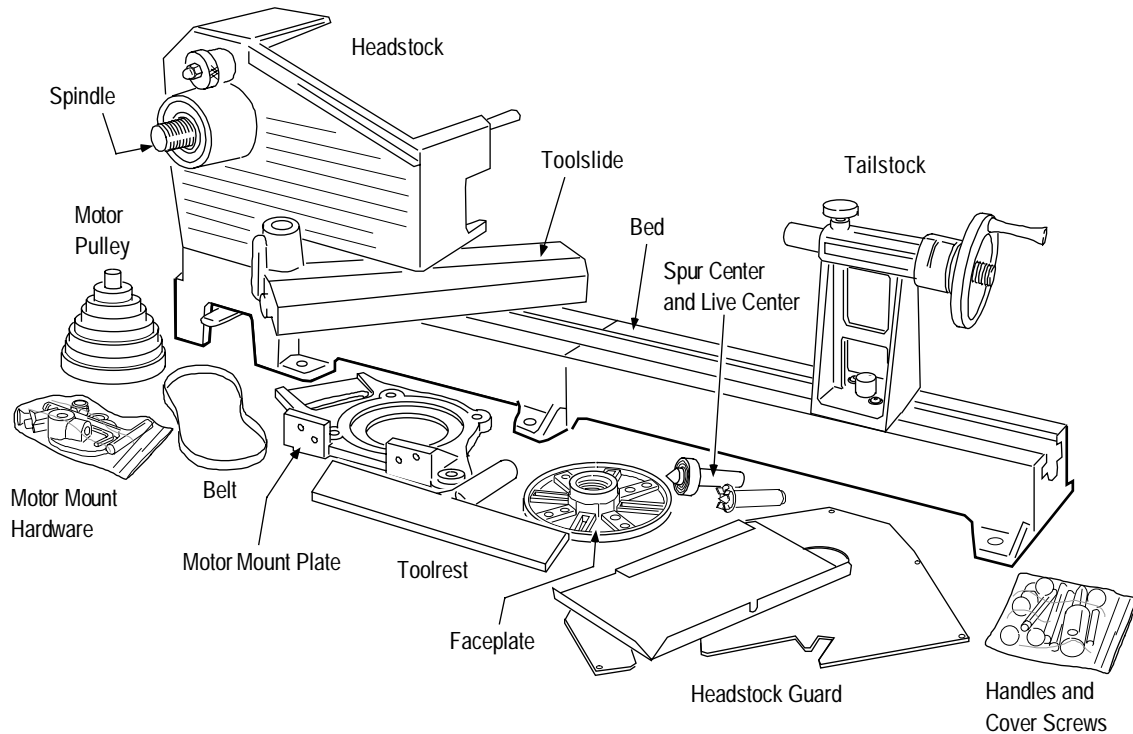

3. Push the Headstock Release Handle down and rotate the Headstock so the spindle points to the tailstock and lines up parallel to the lathe bed.
4. Place the rod through the hole in the Headstock Lockpin and screw on the two ball knobs. Remove the plastic shipping tubing from headstock base. Screw the Lockpin into the threaded hole at the bottom of the headstock. Tighten the Headstock Lockpin to lock the headstock in position.

Installing the Headstock Lockpin

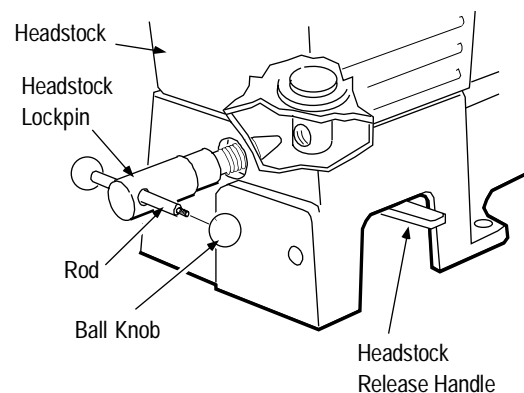

- For Flange Mounted Motor Only. Screw the motor mount plate to the motor using four flathead Allen screws (M6x20 Metric or 3/8 x 1 for USA/Canada). If the motor has an integral on/off switch, make sure the motor is oriented for access to the switch.

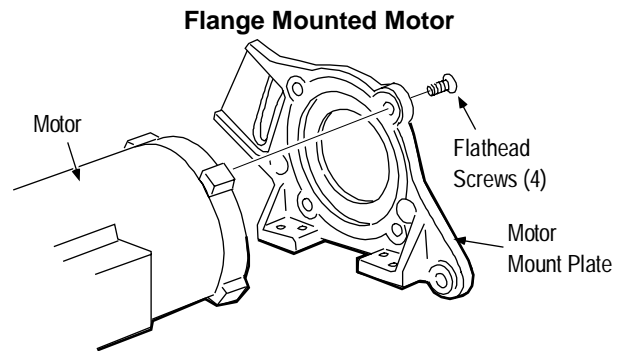

Note: The foot mounting rail kit is an option not included with the standard lathe.

- For Foot Mounted Motor Only. Screw the mounting rails to the motor mount plate using four M8 bolts and washers. Then attach the motor to the rails using four M8 bolts, nuts, and washers.

Adjust the position of the motor on the rails after the pulley is attached (steps 7-10). Then tighten the bolts to firmly secure the motor to the rails.

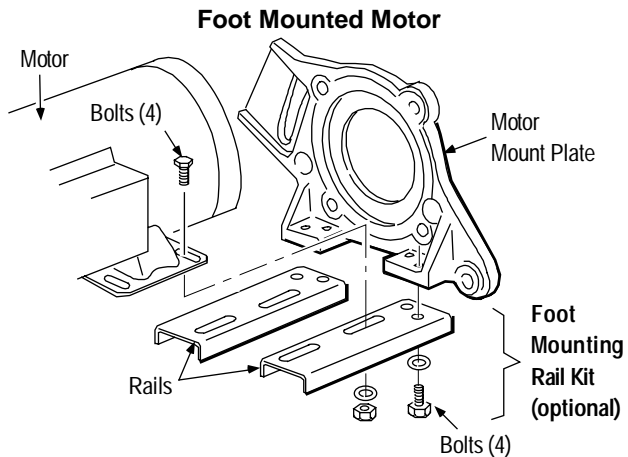

- Fit the key into the motor shaft keyway. Align the keyway in the motor pulley to the motor shaft and slide the pulley onto the motor shaft. Leave about 13 mm (1/2-inch) between the pulley and motor. Loosely secure the pulley to the shaft with an M8x10 set screw with an Allen wrench.

Note: The motor pulley is available with a 5/8-inch bore (US, Canada) or a 19 mm bore (NZ, Australia, Europe, South Africa). Make sure the motor pulley bore is correct for the motor shaft. (The 19 mm pulley has a ring on the boss at the key end to aid identification).

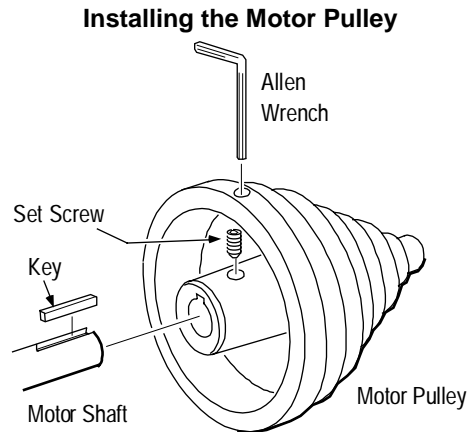

- Place the motor mount plate with attached motor over the headstock studs.
- Place the headstock guard on the headstock; part of it slips between the motor mount plate and the motor pulley. Attach the guard to the headstock with five M5x10 screws. Tighten the screws after the guard has been correctly positioned.
- Install a M12 washer and M12 Nyloc nut on the lower (pivoting) headstock stud. Tighten the nut until the motor mount plate is secure, but movable.
- Place the motor mount cam over the upper (cam) headstock stud. Install a M12 washer and M12 Nyloc nut. Tighten the nut until smooth sliding action is achieved. Screw the Teebar into the cam.

Installing the Motor and Guard

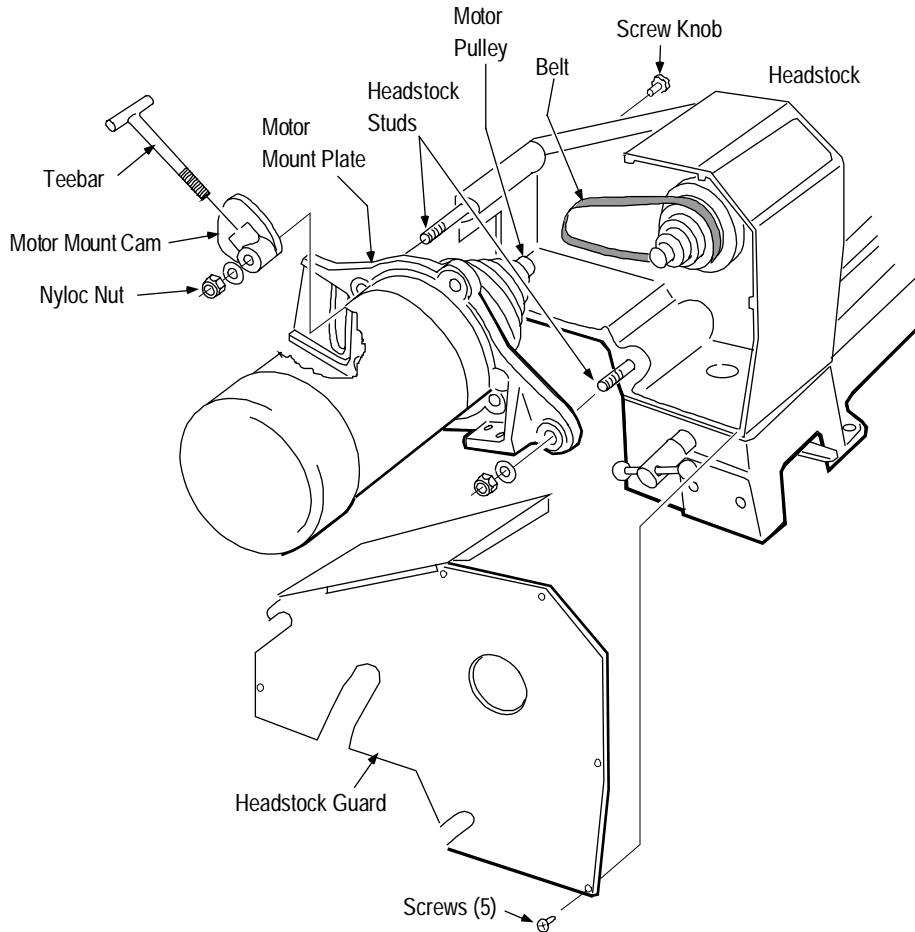

12. Fit the belt over both pulleys. Adjust the position of the motor pulley on the motor shaft so the belt is aligned square between the pulleys. Tighten the M8 set screw on the motor pulley.
13. Push the Teebar away from the lathe to increase the belt tension. Tighten the Teebar to lock the motor in place. Close the guard lid and secure the lid with the screw knob.
14. Assemble the handles:

Note: Some handles may come pre-assembled.

Toolrest Clamp Handle - insert the rod through the handle and screw the ball knobs onto each end of the rod.

Toolside Clamp Handle - screw the rod into the toolside and screw a ball knob onto the end of the rod.

Tailstock Clamp Handle - screw the rod into the tailstock and screw a ball knob onto the end of the rod.

Installing Handles

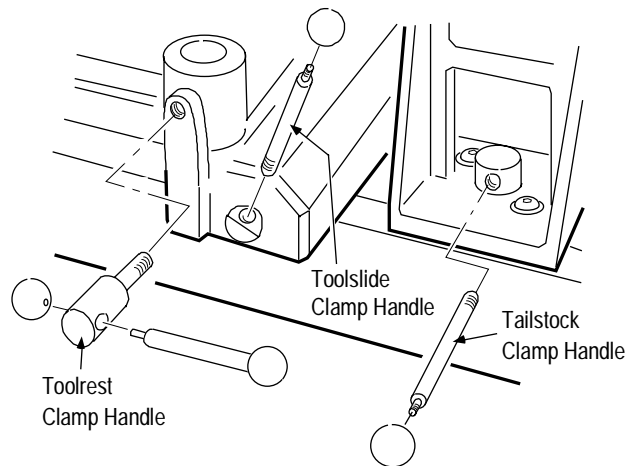

Adding an Extension Bed

Each cast iron extension bed adds 510 mm (20 in.) to the lathe's capacity to turn between centers.

1. Clean the joining ends of both bed sections with a petroleum-based solvent. Make sure there are no dents or burrs on either mating surface. Remove burrs and high spots with a smooth file.
2. Gently tap the two dowel pins into the non-threaded holes of one of the bed sections, until they are flush with the holes inside the casting.

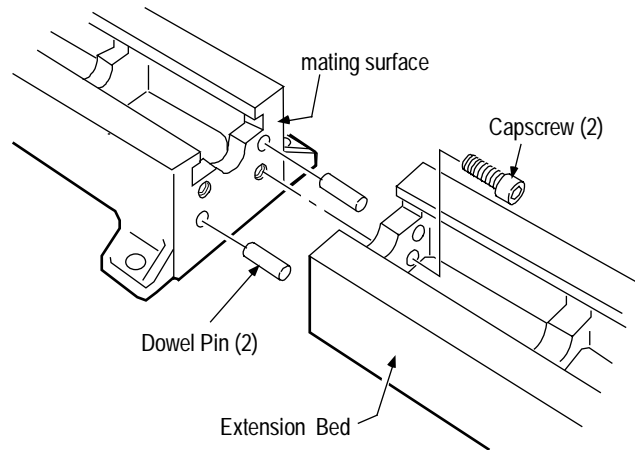

Warning!

Do not use a metal hammer to pound on the extension bed. This may damage the bed, affect accuracy and tailstock action, and may prevent you from adding another extension bed.

3. Line up the dowel pin holes of the add-on extension to the dowels and gently tap the end of the add-on bed with a rubber or wooden mallet until the two beds come together.
4. Secure the bed sections together with two M12x30 capscrews using a 10 mm Allen wrench. It may be necessary to move the lathe so the capscrews can be reached with the wrench from the bottom of the bed.
5. Check that the toolslide and tailstock move freely over the mating joint and also over the full length of the add-on extension. If there is ridge between the two mating surfaces use a smooth file to file the surfaces flush.
6. Follow the suggestions under "Mounting the Lathe to a Support Surface".

Mounting the Lathe to a Support Surface

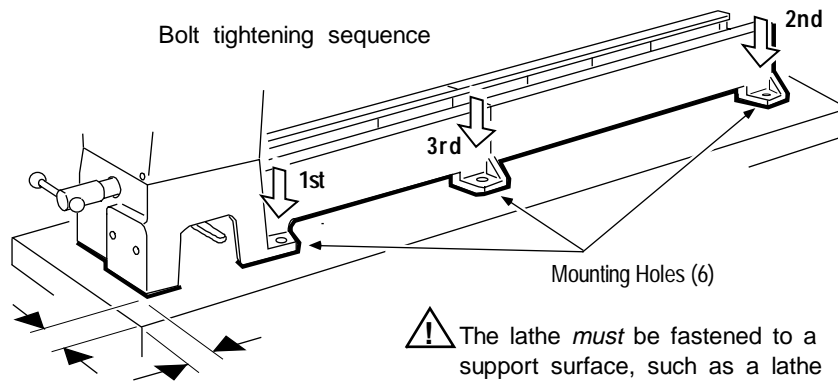

Maximum of 25 mm (1 in.)
(Required only for mounting the
Outrigger Unit option.)

1. Place the lathe on the stand top. Locate the front and left corner of the lathe approximately 25 mm (1 in.) from the corner edge of the stand top. This provides a comfortable reach when turning and allows the optional outrigger unit to be easily installed.
2. If necessary, mark the six hole locations on the top and drill M12 (1/2-inch) holes.
3. Place a spirit level along the top of the lathe bed. Any movement of the bubble as the lathe is secured, indicates a twist on the bed. For the lathe to operate correctly the bed must not twist; if necessary, use shims between the bed and stand top.
4. Use bolts of suitable length (not included) to secure the lathe. Tighten the two headstock bolts first, then the two tailstock bolts, and finally tighten the two middle bolts.

Note: Do not use the M12 threaded holes in the bottom of the lathe for mounting.

Connecting to Power

Follow any instructions that came with the electric motor and switch. The motor should be wired so it rotates in a counter-clockwise direction (when facing the output shaft of the motor). A properly rated on/off switch should be used. DC motor electronic controls may require adjustment for correct operation.

The power cord should be 3-wire, having a grounding conductor and a grounding plug. The plug must be plugged into a matching outlet that is properly installed and grounded in accordance with local electrical codes.



Warning!

Improper connection of the motor can result in a risk of electrical shock.

If it is necessary to use an extension cord, the cord should be grounded. Use the proper wire size for the extension cord, for a given cord length, to avoid power loss and over-heating.

Recommended Extension Cord Size for 1 HP Motor

Cord Length	Wire Size (American Wire Gauge)
0-25 ft (0-7.5 m)	16 AWG
26-50 ft (8-15 m)	14 AWG
51-100 ft (16-30 m)	12 AWG

Using the Nova 3000

Parts of the Nova 3000 Woodlathe

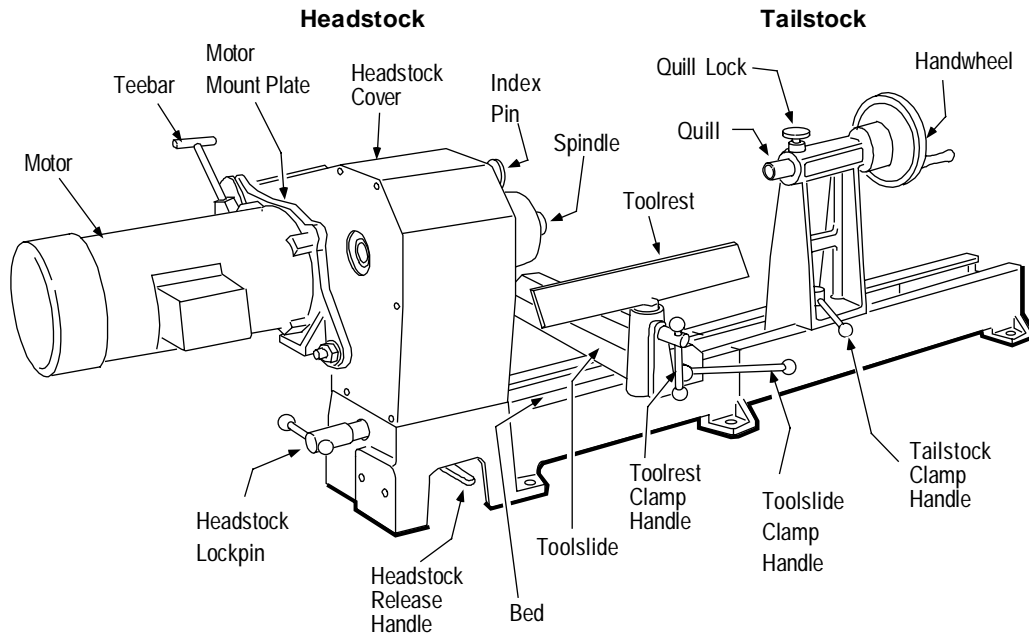

Recommended Turning Speeds

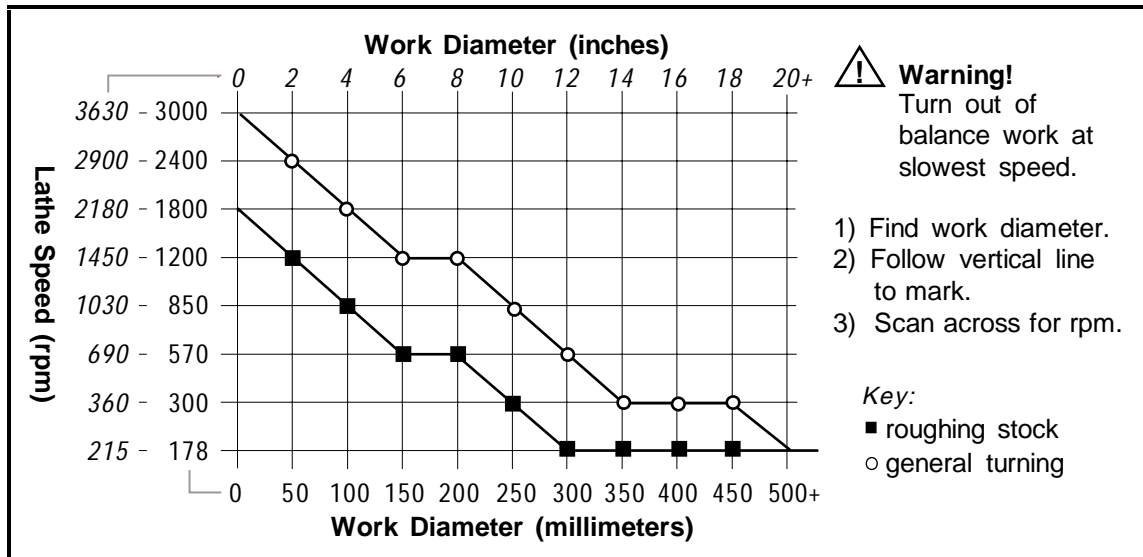

Turning Speeds and DC Motors

Use the electronic variable speed control in combination with the step pulley. Variable speed DC motors may have poor torque (power) at low speeds. Use the lower speed pulley steps for better torque. The available speeds will be from zero up to the maximum speed of the pulley step.

In general, select a belt setting in the lower 4 steps to provide good torque when turning. Use the upper steps only when higher speed spindle turning is required.

Changing Speeds

Speeds are changed by moving the belt position on the two 8-step pulleys. The speeds vary due to the rpm's of the motor. Speed position can be checked by viewing the belt through the window at the front of the headstock.

Lathe Speed Selection

Country	Motor rpm	Lathe Speeds (rpm)
United States, Canada	1725	215, 360, 904, 1030, 1450, 2180, 2900, 3630
Australia, New Zealand, UK, Europe, South Africa	1425	178, 300, 570, 850, 1200, 1800, 2400, 3000



Warning!

Don't apply excess tension to the belt. You should be able to push the belt down at the center point between the pulleys from 8-12 mm (5/16 – 1/2 inch) with your thumb. Excess belt tension can cause increased vibration, bearing wear, belt wear, and damage to the motor shaft.

1. Stop the lathe.
2. Loosen the screw knob and open the headstock guard.
3. Loosen the Teebar and pull the lever toward the front of the lathe to loosen the belt. Tighten the teebar to hold the motor while the belt position is changed.
4. Position the belt on the selected set of pulleys.
5. Push the Teebar away from the lathe to tension the belt and tighten the teebar.
6. Close the headstock guard and tighten the screw knob.

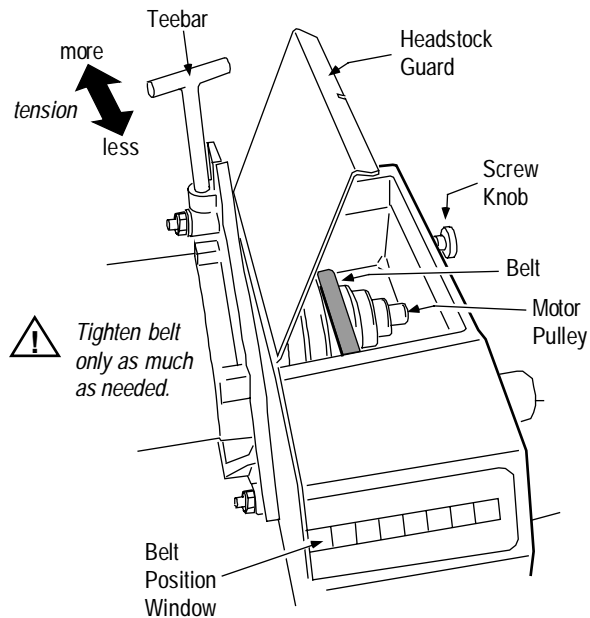

Swiveling the Headstock

1. Stop the lathe.
2. Loosen the Headstock Lockpin one turn, push the Headstock Release Handle down, and rotate the headstock to a detent position (0, 22.5, 45, and 90 degrees). The 180 and 337.5 degree positions are supplied for left-hand turning applications.



Warning!

Use the detent latch positions to prevent headstock movement during turning.

3. Tighten the Headstock Lockpin.

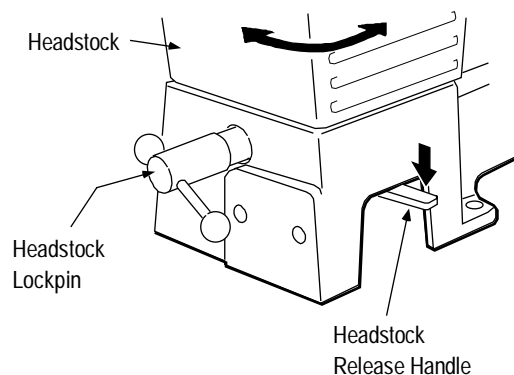

Spindle Index

The spindle index pin locks the headstock spindle. It is selectable in 15 degree increments (24 divisions). There is sight hole to read index numbers (0 through 23).

1. Stop the lathe.
2. Pull the index knob and turn it left until the pin drops into the hole. To lock the spindle it must engage into a hole in the headstock pulley.

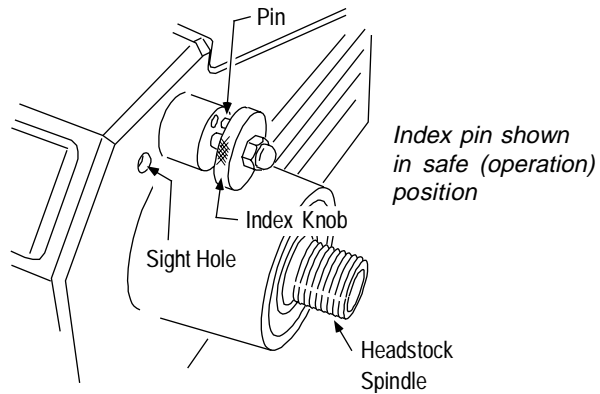

Warning!

Make sure the index pin is out before operating the lathe. The pin should drop into the indentation in the headstock to prevent it from engaging while the spindle is turning.

<i>Divisions</i>	<i>Index Number</i>	<i>Degrees</i>
2	0,12	180
3	0,8,16 (every 8th)	120
4	0,6,12,18 (every 6th)	90
6	0,4,8,12,16,20 (every 4th)	60
8	0,3,6,9,12,15,18,21 (every 3rd)	45
12	0,2,4,6,8...22 (every 2nd)	30
24	every hole	15

Headstock

The headstock houses the motor pulley, headstock pulley, bearings, and the spindle. The headstock spindle accepts centers and accessories with no. 2 Morse taper (#2 MT), plus threaded faceplates and chucks.

Spindle Thread Size

<i>Country</i>	<i>Threads</i>
United States, Canada	1-1/4 x 8 TPI RH
Australia, New Zealand, UK, Europe, South Africa	M30 x 3.5 RH

Mounting a faceplate or chuck

1. Use the spindle Index Pin to lock the headstock spindle.
2. Screw the faceplate or chuck onto the spindle threads. A spindle washer in-between may be used to make removal easier.



Warning!

The faceplate or chuck body must contact the shoulder on the spindle bearing.

3. Pull and turn the Index Pin and place it in the "safe" indentation in the headstock.

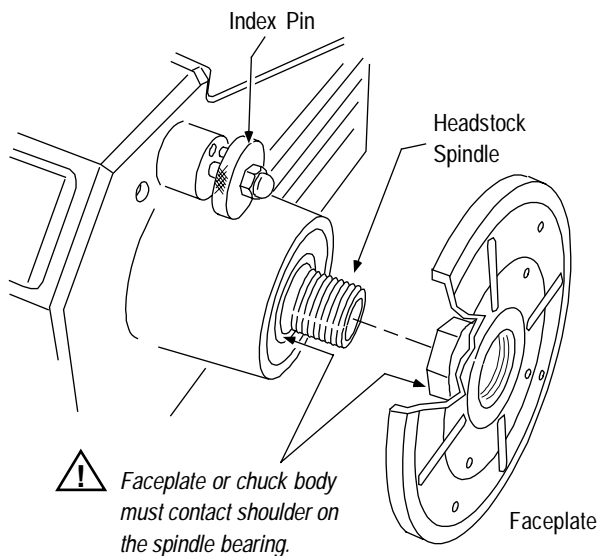

Using a spur center

Mount the spur center to the work piece as shown and then insert the spur center and work piece into the headstock spindle.



Warning!

Do not pound work piece into headstock drive center when turning between centers or you may damage the headstock.

To remove the center, insert a 10 mm (3/8-inch) diameter wooden dowel or steel rod through the headstock spindle hole. While holding the center so it doesn't fall, tap it out.

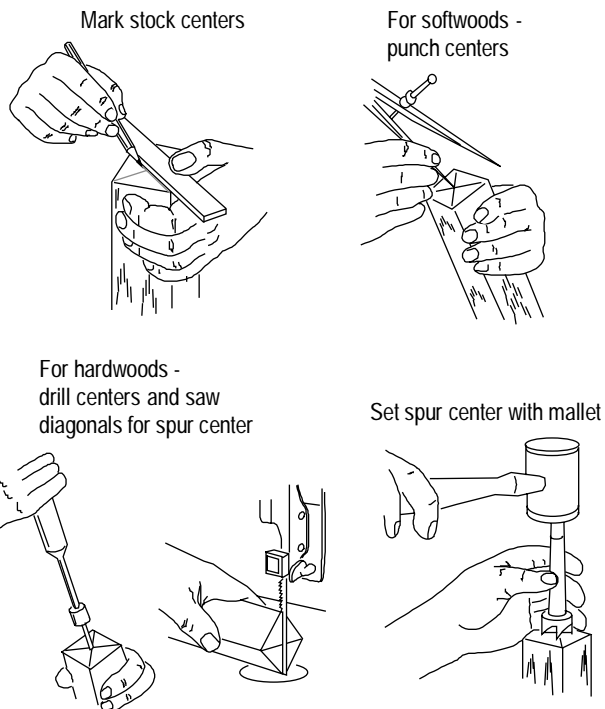

Toolrest

To move the toolslide along the bed, loosen the Toolslide Clamp Handle, move the slide to the desired position, and tighten the clamp handle.

To adjust the toolrest, loosen the Toolrest Clamp Handle, position the toolrest, and tighten the clamp handle.

Adjust the toolrest close to the work piece. Exact positioning may be varied to suit the turner. Before turning, revolve the stock by hand to make sure it clears the rest. At intervals, stop the lathe and readjust the toolrest.



Warning!

Lathe tools and chisels should remain on the toolrest whenever the tool is in contact with the work piece.

Remove the toolrest when sanding or polishing so fingers do not get pinched.

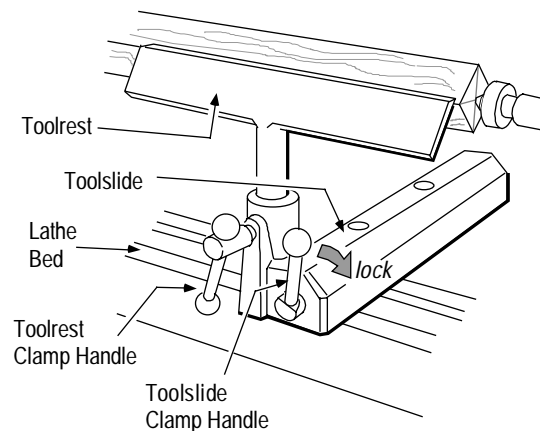
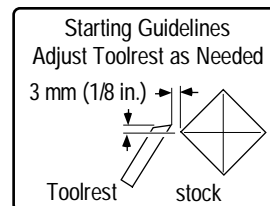

Tailstock



Warning!

Never loosen the tailstock quill or tailstock while the work piece is turning.

To move the tailstock along the bed, loosen the Tailstock Clamp Handle, slide the tailstock to the desired position, and tighten the clamp handle.

To move the tailstock quill in or out, loosen the Quill Lock and turn the Handwheel. Lock the quill in place with the Quill Lock.

The tailstock quill accepts centers and accessories with no. 2 Morse taper (#2 MT). To install a taper use a quick, firm action by hand. Do not pound the taper in.

To remove a taper, insert a 10 mm (3/8-inch) diameter wooden dowel or steel rod through the tailstock quill hole. While holding the taper so it doesn't fall, tap it out.

The tailstock quill is hollow, allowing you to bore holes through turnings if a hollow center is used.

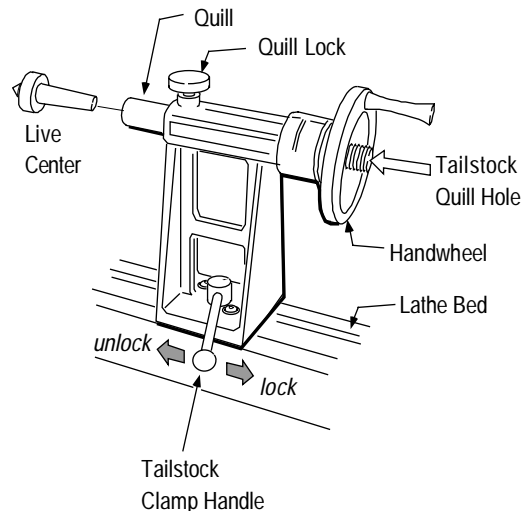

Adjusting the Tailstock for Turning Between Centers

1. Mount the spur center to the work piece and insert the spur center into the headstock spindle, as previously described under "Using a Spur Center".



Warning!

Do not use the tailstock quill action to drive the work piece into the spur center. This can create an unsafe and loose work piece.

2. Mount the live center into the tailstock quill using a quick, firm action by hand.
3. While holding the work piece, slide the tailstock to meet it and lock the tailstock in place. Turn the Handwheel to apply light holding pressure to the work piece; it should turn easily by hand, yet not be loose. Tighten the Quill Lock.

Learning Turning

The art and technique of turning is a subject beyond the scope of this instruction manual. It is recommended that you receive hands-on instruction on lathe turning and/or refer to books and videos on the subject. For reference, some woodturning books are:

Woodturning A Foundation Course
by Keith Rowley

Creative Woodturning
by Dale Nish

Turning Wood With Richard Raffan
by Richard Raffan

The Fundamentals of Woodturning
by Mike Darlow

Maintaining the Nova 3000

General Maintenance

<i>Interval</i>	<i>Maintenance</i>
After each use	Clean the work area and lathe. Vacuum scraps and dust from the inside the headstock, between the lathe bed rails, and under the toolslide and tailstock.
Monthly	Wax exposed cast iron parts with a good quality paste wax, especially the bed rails. Buff out the wax thoroughly. Check tightness of nuts and bolts; especially the set screws on the motor pulley and headstock pulley, and the lathe mounting bolts. Lubricate, with one or two drops of light-weight oil, the tailstock quill threads, index pin shaft, and the toolslide camshaft (remove plastic plugs) and toolslide front camshaft bore.
6 Months	Grease tailstock quill threads. Turn the handwheel so the quill threads are exposed, apply grease to the threads, crank the handwheel back and forth to work in the grease, wipe off any excess. Lubricate the tailstock slot with one or two drops of light-weight oil.

Lubrication Locations

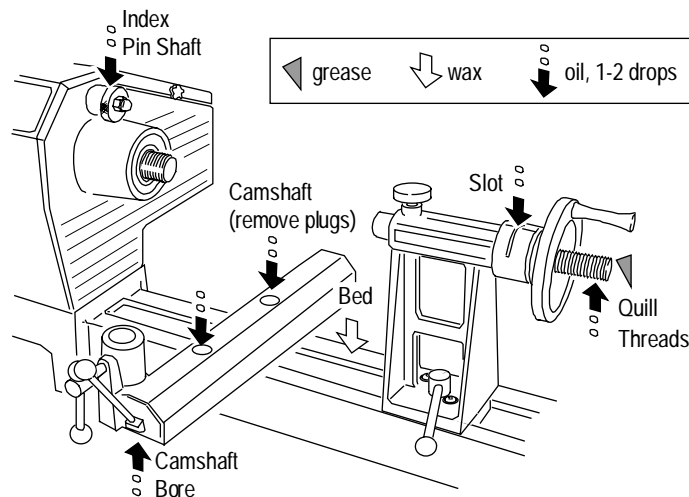

Cleaning the Toolslide

If the toolslide becomes hard to move and adjust, cleaning and lubricating are required.

1. To make the toolslide slide more freely along the bed, make sure the bed rails are clean. Apply some paste wax to the rails.
2. If the toolslide is hard to move towards or away from you, remove the toolslide from the lathe bed. Clean the toolslide camshaft (round eccentric rod) with a petroleum-based solvent. Lubricate the rod with a light-weight oil or a silicone spray.
3. Slide the base back onto the lathe bed.

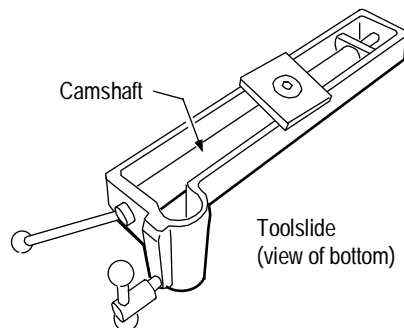

Cleaning the Tailstock

If the tailstock quill becomes hard to use or the Handwheel is hard to turn, cleaning and lubricating are required.

1. Remove the 6 mm set screw from the tailstock. If necessary, turn the Handwheel to expose the set screw.
2. Using a screwdriver, remove the keeper plate from the tailstock body.
3. Remove the quill and Handwheel from the tailstock body.
4. Wipe clean all parts including the inside of the tailstock.
5. Lubricate the quill and tailstock slot with a light-weight oil and apply a small amount of grease to the quill threads.
6. Reassemble.

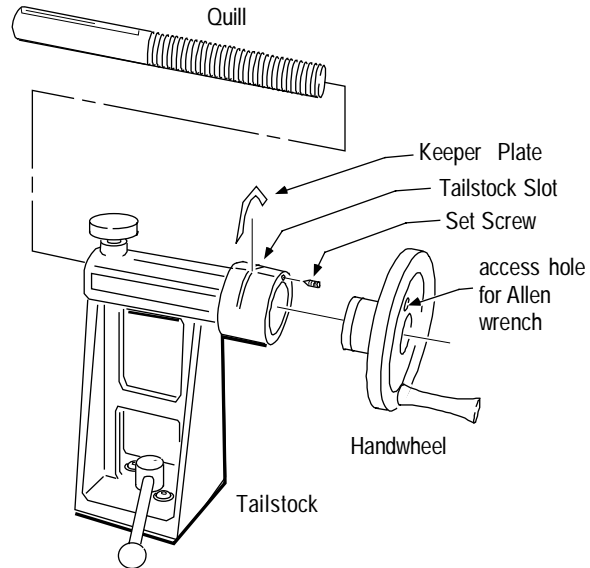

Aligning the Tailstock

1. Crank the Handwheel so the quill is all the way in.
2. Place any #2 MT accessory you have that has a sharp point like a spur center, or live center in the tailstock quill and another center in the headstock spindle.

Note: Tailstock alignment can be made easier by using the Teknatool AcruLine Accessory Center in place of the centers.

3. Move the tailstock close to the headstock so the two centers nearly touch; check the alignment of the center points. Move the tailstock away from the headstock and extended and lock the quill. The points of the centers should align when the quill is halfway extended, fully extended, and fully retracted. If the centers are aligned at all three locations no adjustment is necessary. If the tailstock does not meet the conditions in step 3, follow the steps below. This indicates that the tailstock is not parallel to the lathe bed and you will need to realign the tailstock.
5. First make sure the tailstock alignment plate is not binding inside the bed. If the tailstock doesn't move freely then remove the tailstock and look for burrs or high spots on the bed rails or the alignment plate. Using a smooth file remove any burrs or high spots. When done replace the tailstock on the bed.
6. Slightly loosen the two tailstock cap screws with an Allen wrench. Tap the tailstock with a wooden mallet in the appropriate direction to align the centers. Check and adjust the positioning of the tailstock. The centers should align when the quill is halfway extended, fully extended, and fully retracted, as previously described in step 3.
7. Lock the tailstock in place with the Tailstock Clamp Handle and fully tighten the two cap screws. The cap screws must be fully tightened in order to avoid slippage during work.

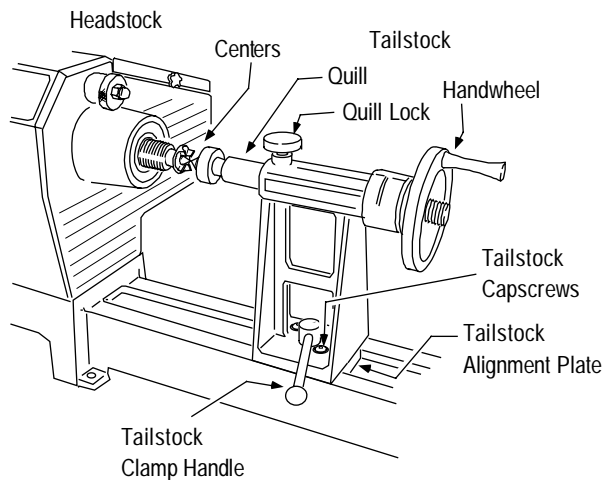

Troubleshooting Guide

<i>Problem</i>	<i>Possible Cause and Solution</i>
<i>Excessive vibration.</i>	<p>Out of balance, or large work piece. Reduce lathe speed to the lowest speed possible and turn the work piece to a true circle.</p> <p>Work piece is not held in the center. Check work piece mounting and correct.</p> <p>Work piece is not secure or held tight enough. Check work piece mounting and correct.</p> <p>Lathe incorrectly bolted to stand or bench. Refer to this manual for lathe stand recommendations.</p> <p>Stand or bench not well constructed, too light, or standing incorrectly on the floor. Make sure the stand is solidly constructed. Use sand bags to weigh down the stand.</p> <p>Over tensioning of belt is a primary cause of vibration. The drive belt is running badly, over tensioned, or damaged. Apply a spray-on belt dressing on the belt grooves, readjust belt tension, or replace the belt.</p> <p>Motor pulley is not in correct alignment with the headstock pulley. Loosen the motor pulley set screw and align the pulleys.</p> <p>Headstock is loose. Tighten the Headstock Lockpin.</p> <p>Headstock pulley or motor pulley is loose. Check that the pulley set screws are tight.</p> <p>The headstock guard is loose or rattling. Check that the guard screws are tight.</p> <p>Movement in motor mount plate. Check that the nyloc nuts on the headstock studs are tight, and that the Teebar is tight.</p> <p>Motor vibrates. Many single phase motors due to their design produce minor noise or vibrations; these usually cannot be altered.</p>
<i>Faceplate or chuck running out of true.</i>	<p>Dirt build up on the rear of the faceplates or chuck. Clean off all build up and dirt. Faceplates and chucks must mount securely against the inner bearing ring surface of the spindle.</p>
<i>Turning tools not sliding smoothly across Toolrest.</i>	<p>Damaged surface on toolrest face caused by sharp edged tools. File the toolrest using a fine smooth file and polish with extra fine sandpaper. Also remove the sharp edges from the corners of turning tools.</p>
<i>Spur drive center or live center not holding into the spindle taper or quill taper when turning.</i>	<p>Small end of Morse taper is damaged due to dropping or hitting. File or polish away any damage. Check that inside of tapers have not been scored.</p> <p>Grease or oil inside of Morse tapers. Wipe clean the inside of the tapers.</p> <p>Insufficient pressure when installing the center. Use a quick, firm action by hand to install a taper. Do not knock in using any solid object.</p>

Troubleshooting Guide

<i>Problem</i>	<i>Possible Cause and Solution</i>
<i>Tailstock and headstock center not lining up correctly.</i>	<p>Tailstock not aligned to headstock; adjust as described under "Aligning the Tailstock".</p> <p>Bed incorrectly bolted to stand causing twist. Ensure stand and lathe are correctly installed.</p> <p>Headstock not returned to detent position after it has been rotated. Ensure that the headstock is locked into a detent position.</p> <p>Headstock Lockpin not fully seated. Give the handle a twist back and forth to make sure it is properly seated.</p> <p>Dirt or wood dust accumulated in the headstock swivel pin hole. Remove the Headstock Lockpin and clean out hole.</p>
<i>Clicking noise in headstock when lathe is operating.</i>	<p>Headstock pulley or motor pulley loose. Check that the pulley set screws are tight.</p>
<i>Tailstock handwheel hard to turn or will not turn.</i>	<p>Quill lock is locked; unlock the quill lock. If necessary, lightly tap a block of wood against the handwheel handle; tap the handle in a clockwise direction as viewed from the tailstock end.</p> <p>Build up of dust and wood resin on the quill or inside of the handwheel thread. Remove, clean, and lubricate the quill and tailstock as described under "Cleaning the Tailstock".</p> <p>The quill has been extended too far and is locked against the handwheel. Push the quill back into the tailstock when turning the handwheel.</p>
<i>Tailstock quill hard to move.</i>	<p>Quill lock is locked; unlock the quill lock.</p> <p>The quill is damaged; turn the handle to expose the quill and check for marks along the quill, especially on the edges of the slotted keyway. Remove the high spots with a smooth file and test the quill travel. Replace the quill if necessary.</p>
<i>Tailstock not locking correctly onto bed, or tailstock not sliding smoothly on bed ways.</i>	<p>Tailstock adjustment plate not adjusted correctly; adjust as described under "Aligning the Tailstock".</p> <p>Dirty bed ways and underside of tailstock body. Clean bed ways and underside of tailstock body with a petroleum-based solvent.</p>
<i>Tailstock binds.</i>	<p>The inside of the bed has a high spot. File the area with a smooth flat file until the tailstock moves freely.</p> <p>The tailstock adjustment plate has a rough spot or a burr. Remove the tailstock and file the plate with a smooth flat file.</p>
<i>Tailstock jumps where bed sections join.</i>	<p>The machined flat surfaces are not flush. File the area with a smooth flat file until the tailstock moves freely.</p>

Nova 3000 Woodlathe Parts List

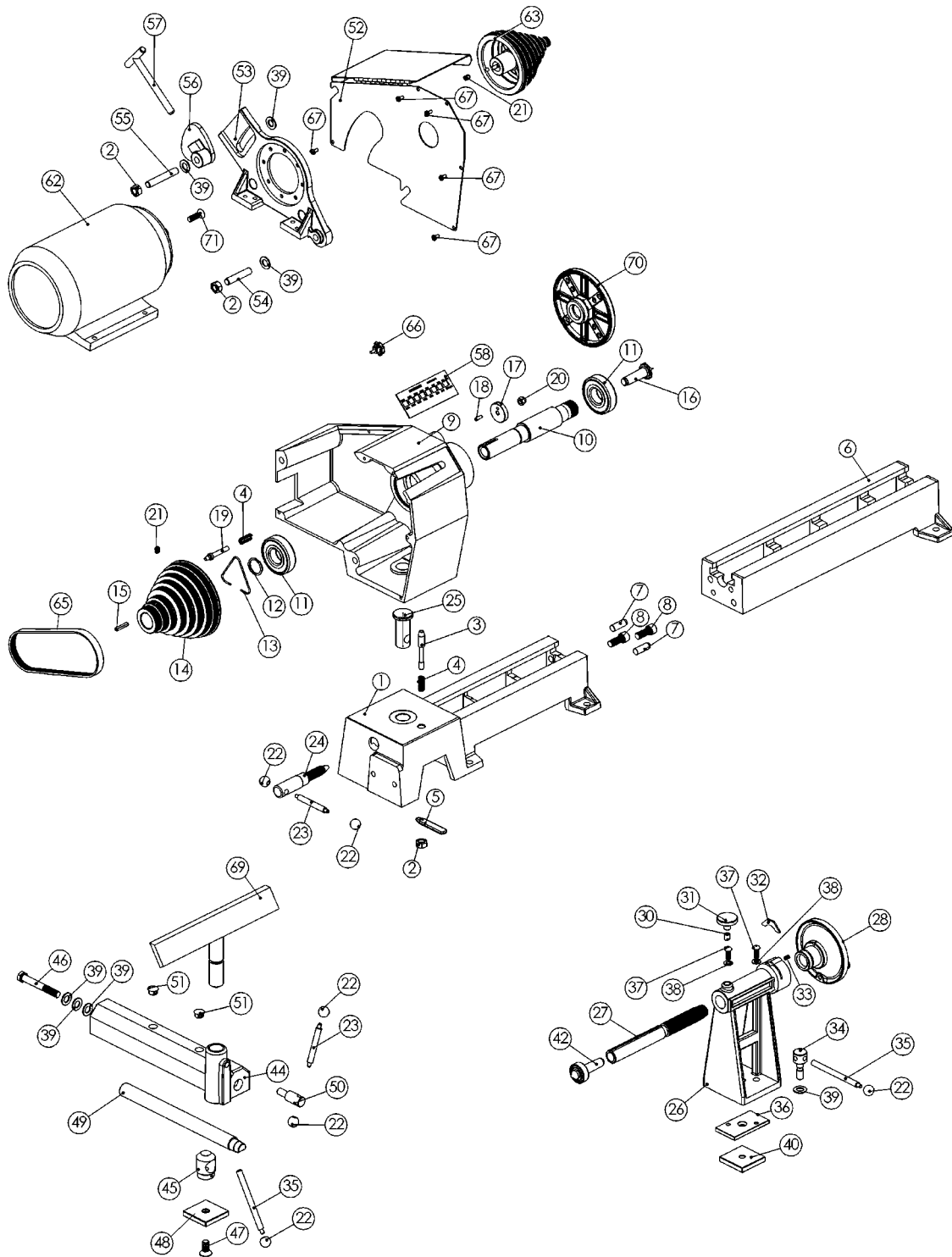

Nova 3000 Woodlathe Parts List

Most items are applicable to all countries; items listed with an "A" are applicable to United States and Canada; items listed with "B" are applicable to New Zealand, Australia, UK, Europe, and South Africa.

<i>Item</i>	<i>Qty</i>	<i>Part No.</i>	<i>Description</i>	<i>Item</i>	<i>Qty</i>	<i>Part No.</i>	<i>Description</i>
1	1	24000	Main Lathe Bed	35	2	24016	Lock Arms
2	3	NN12	Nut Hex Nyloc M12 ZP	36	1	24047	Plate Adjustable Alignment
3	1	24023	Detent Pin D12 G/F #19	37	2	BHC08020	Capscrew Button Head M8 x 20
4	2	201437001	Compression Spring	38	2	FW8	Washer Flat M8 x 16 ZP
5	1	24012	Detent Pin Handle	39	7	FW12	Washer Flat M12 ZP 1.6 mm Thick
6	1	24001	Bed Extension Unit	40	1	24008	Lockplate Tailstock M12 ZP 1.6 mm Thick
7	2	24041	Dowel Pin M12 x 36	42	1	2MTLC	Live Center #2MT
8	2	24011	Capscrew M12 x 30	44	1	24009	Toolslide Casting
9	1	24002	Headstock	45	1	24048	Cam Nut Toolslide
10A	1	24045	Spindle Headstock 1-1/4 x 8 TPI	46	1	BNMZ12090	M12 x 90 Eng Bolt
10B	1	24024	Spindle Headstock M30 x 3.5	47	1	K1225	M12 x 25 Allen Head Flathead Screw
11A	1	6306LLB	NTN 6306 Bearing	48	1	24042	Plate Toolslide Lock
11B	1	6207	SKF 6207-2RSI Bearing	49	1	24020	Camshaft Toolslide
12	1	20134700	Circlip External 30mm (1.5 mm wide)	50	1	24026	Teelock Body
13	1	98034700	Wire Form Circlip	51	2	HP-16	Plughole M16 Black
14	1	24025	Pulley Headstock	52	1	201105000	Guard Headstock
15	1	3.16KEY	3/16 in. SQ Key in M/S x 30 mm	53A	1	24054	Flange - Motor Mount NEMA 56C
16	1	2MTSPUR	Spur Center #2MT	53B	1	24027	Flange - Motor Mount Metric
17	1	201455000	Spindle Index Knob	54	1	24050	Stud M12 x 60 Motor Mount
18	1	201360001	Bissel / Tension Pin 3/16 in. x 5/8	55	1	24051	Stud M12 x 75 Motor Mount
19	1	201395200	Spindle Index Pin	56	1	24046	Cam Casting for Motor Mount
20	1	DNNO8	M8 Brass Dome Nut	57	1	24049	Teebar - Motor Mount
21	2	G0810	Set Screw M6 x 10 Knurled Point	58	1	24015	Speed Indicator Label
22	6	865913	Ball Knob 3/4 in. DIA with M6 thread	62			Motor
23	2	25001	Teelock Arm M10 DIA x 85 with M6 threads	63A	1	MPWL	Motor Pulley 8 step 5/8 in. Shaft
24	1	24004	Headstock Lockpin	63B	1	MPWL19	Motor Pulley 8 step M19 Shaft
25	1	24031	Swivel Pin Headstock	65	1	610J6	Belt Poly Vee
26	1	24039	Tailstock Adjustable Type	66	1	24055	M5 x 10 Knob (guard cover)
27	1	203405000	Quill Tailstock 1 in. DIA with M10 LH thread	67	5	MP05010	Screw Pan Head Pozi M5 x 10 ZP
28	1	24043	Handwheel Tailstock	69	1	TR300/1	Toolrest 300 mm with 1 in. DIA post
30	1	27001	Key Quill Lock	70A	1	FP150Y	Faceplate 150 mm with 1-1/4 x 8 TPI
31	1	24019	Quill Lock Knob - Key Type	70B	1	FP150	Faceplate 150 mm with M30 x 3.5
32	1	24040	Keeper Plate - Hardened steel	71A	4	KC0608	3/8 x 1 UNC Allen Head Flathead Screws
33	2	G06010	Set Screw M6 x 10 Knurled Point	71B	4	Motor Screws	M6 x 20 Allen Head Flathead Screws
34	1	27000	Lock Stud Tailstock				

Accessories

Add On Bed Extension

Extend the bed of your Nova 3000 Woodlathe for greater capacity for turning between centers. Each bed unit adds 510 mm (20 in.)

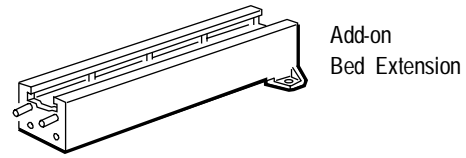

Lathe Stand

Strong, rigid, 4 mm thick sheet metal lathe stand, 86 cm (34 in.) high for the Nova 3000. The legs have an extra flange to allow you to insert a piece of plywood to create a boxed leg for filling with sand for even extra vibration dampening. The stand is available in two models one to fit the standard Nova 3000 and one to fit an additional add-on extension bed.

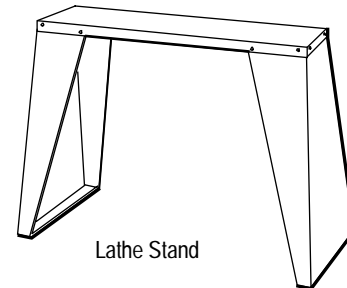

SuperNova Chuck

A next-generation, self-centering chuck to securely hold round and square work pieces for centerless turning. The special Tuff Lock gearing delivers amazing holding power in both the contraction and expansion mode. It has an open-back for easy cleaning and can be tightened one-handed with an articulated key. It includes a screw chuck. A wide variety of optional jaws are available to hold almost any work piece.

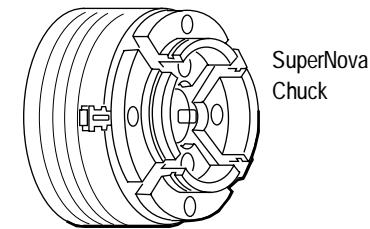

Small Toolrest

A small 100 mm (4 in.) toolrest (not shown) for turning small work pieces or reaching into recessed areas.

Bowl Toolrest

A curved toolrest which gives you better chisel support on both the outside and inside of a bowl. Because of the curve you are able to position your chisel support closer to the bowl.

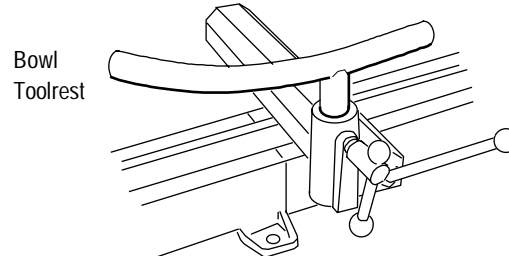

Revolving Center System

A multi-function live center system to expand your options when turning between centers. It includes quick change tapers: a hollow cup center point, threaded center, cone center, and an extension center. Made with three bearings and precision machined for a high quality finish.

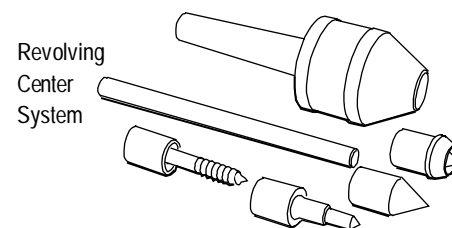

Handwheel Unit

The handwheel is mounted on the outboard end of the headstock spindle so you can manually position work or to slow it down. The vacuum coupler can also be added to this unit to make a vacuum holding option.

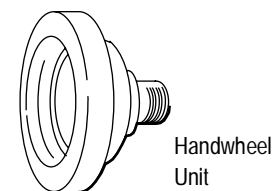

Accessories

Faceplates

Faceplates are used to mount the work piece when faceplate turning bowls or platters. Faceplates are available in 80 mm (3 in.) and 150 mm (6 in.) diameters. A vacuum faceplate is also available.

The 80 mm (3 in.) faceplate is made of solid steel. This faceplate has a small contact area to allow maximum freedom while shaping. The 150 mm (6 in.) faceplate is made of light-weight aluminum and has a unique indexing feature. It can handle large work pieces up to 740 mm (29 in.) in diameter.

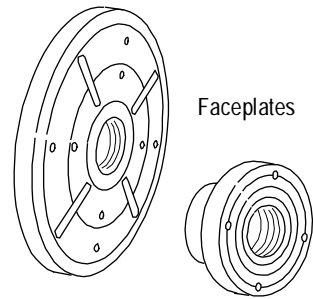

Vacuum Coupler

The Vacuum Coupler (not shown) fits onto the Handwheel Unit. It provides a secure attachment for your vacuum cleaner hose. For those turners who are interested in vacuum chucking, this is a simple system.

Outrigger Unit

Extend the bowl turning capacity of the Nova 3000 Woodlathe to up to 740 mm (29 in.) in diameter. This unit is made from cast iron, is easy to position and control, and mounts to the headstock end of the lathe.

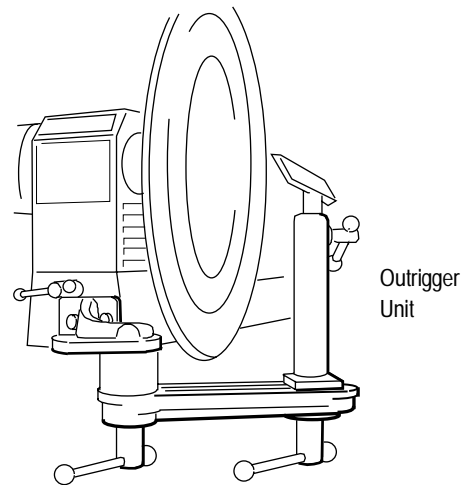

Nova Ornamental Turner

This unique and innovative accessory allows you to easily add an endless array of decoration, ornamentation and threading to your work. Precision machined, this unit is easy to position and control and mounts to the bed unit of your Nova 3000 lathe. A wide range of accessories, comprehensive manual and video are also available.

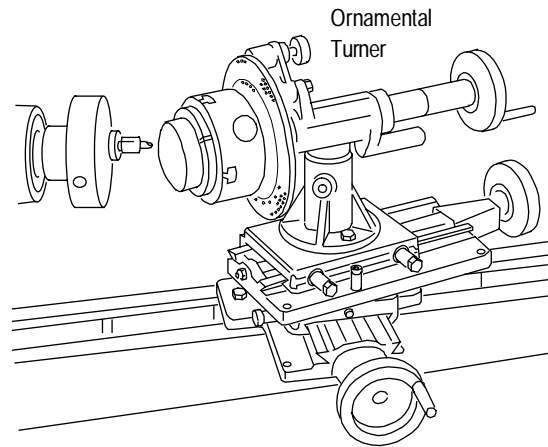

For further details about Teknatool's lathe accessories please contact your local retailer for more information, or contact us directly. Visit our website at www.teknatool.com.

Index

- AC Motors, 6, 8
- Accessories, 25, 26
- Aligning the tailstock, 20
- Assembling, 9
- Bed, lathe, 12, 25
- Belt Tension, 15
- Bowl version, 6
- Camshaft, 19
- Centerless turning, 16
- Centers, 9, 17, 18
- Changing Speeds, 15
- Chuck, 16, 25
- Cleaning, 19, 20
- Components, 9, 14
- Connecting to power, 13
- Contents, 3
- DC Motors, 6, 8, 14
- Distance between Centers, 6
- Electrical, 13
- Extension Bed, 12, 25
- Extension Cords, 13
- Faceplate, 9, 16, 26
- Handles, 9, 11, 14
- Handwheel, 25
- Headstock Lockpin, 9, 14, 15
- Headstock, 6, 14, 16
- Hiturn Sharpening Center, 26
- Lathe Stand Requirements, 7, 13
- Live Center, 18
- Lubrication, 19
- Maintenance, 19
- Motor Mounting, 10
- Motors, 6, 8
- Mounting faceplate or chuck, 16
- Mounting, lathe, 6, 13
- Names of components, 14
- Nova 3000 parts, 14
- Nova 3000 specifications, 6
- Oil, 19
- Operating, 15-18
- Ornamental Turner, 26
- Outrigger Unit, 26
- Parts listing, 23, 24
- Parts of the Nova 3000, 9, 14, 23, 24
- Power, 13
- Problems, 21
- Quill, 6, 14, 20
- Revolving Center System, 25
- Rpm, 15
- Safety, 4, 5
- Sanding, 17
- Shop requirements, 7
- Specifications, 6
- Speed, 14, 15
- Spindle Index, 16
- Spindle threads, 6, 16
- Spur center, 9, 17
- Stand, 7, 13, 25
- Standard Equipment, 6
- SuperNova Chuck, 16, 25
- Swing, 6
- Swiveling the headstock, 15
- Tailstock parts list, 24
- Tailstock, 6, 14, 18, 20
- Teebar, 10, 11, 14, 15
- Teknatool, 2
- Toolrest options, 25
- Toolrest parts List, 24
- Toolrest, 6, 14, 17, 19
- Troubleshooting, 21
- Turning between centers, 18
- Turning speeds, 14
- Turning the headstock, 15
- Turning, 18
- Unpacking, 9
- Vacuum Coupler, 26
- Vibration, 21
- Warranty, 28
- Website, 2
- Work diameters, 6, 14
- Workshop requirements, 7

Teknatool Five Year Limited Warranty

This Teknatool product is backed by a FIVE YEAR warranty from the date of purchase. Teknatool International Ltd. will repair or replace, at its expense and option, this Teknatool product which in normal use has proven to be defective in workmanship or material, provided that the customer returns the product prepaid to an authorized Teknatool service center with proof of purchase of the product within TWO YEARS and provides Teknatool with reasonable opportunity to verify the alleged defect by inspection. Furthermore, Teknatool International Ltd. extends this two year period for three additional years, excluding labor costs and drive belts, provided the aforementioned conditions are met. Motors and electronic controls are not covered under this warranty; these are warranted by their respective manufacturer.

Teknatool will not be responsible for any asserted defect which has resulted from normal wear, misuse, abuse, or repair or alteration made by anyone other than an authorized service facility or representative. Under no circumstances will Teknatool International Ltd. be liable for incidental, special, indirect, and consequential damages or expenses, including loss of profits or loss of operations. This warranty is Teknatool International Ltd. sole warranty. There are no other warranties, whether written or verbal, whether expressed or implied by law, trade, custom, or otherwise, whether of merchantability, fitness for purpose, or otherwise, except for remedies available to customers under the Consumer Guarantees Act or other legislation.

OVERSEAS CUSTOMERS: Our Teknatool Distributors and agents will issue their own warranty to cover this product. Terms may vary from those stated above; please check with your dealer.

