

# Nova 1624 Stand

**For safety reasons please carefully read and understand these instructions.**

The Nova 1624 Stand is designed to fit and be used only with the Nova DVR and 1624-44 Woodlathe. Use of the 1624 Stand on other lathes could cause a malfunction and risk of serious injury.

If you are unsure of the use or application of this accessory contact the technical manager of Teknatool International or your reseller.

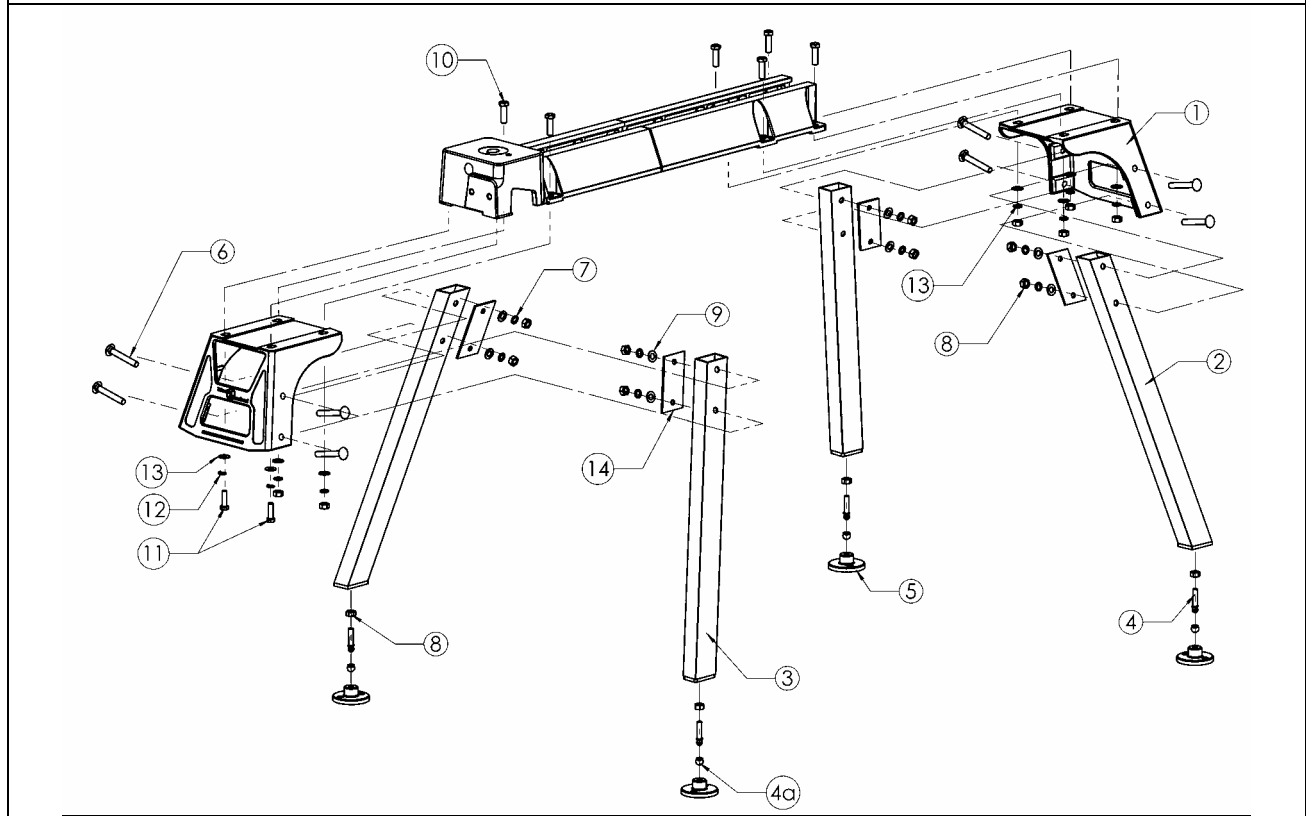

## Parts List

Part	Code	Description	No
1	25045	Cast Iron Frame	2
2	25046	Leg Stand RHS R	2
3	25047	Leg Stand RHS L	2
4	25050	Bolt Ball Pin	4
4a	25051	Rubber Bushing	4
5	25052	Casted Foot	4
6	CBNZ12090	Coach Bolt M12x90	8
7	SW12	Spring Washer M12	14
8	NHZ12	Nut Hex ZP M12	18
9	FW12	Heavy Flat Washer M12	14
10	BNMZ12040	Bolt Hex M12 x 40	6
11	BNMZ10035	Bolt Hex M10x 35	2
12	SW10	Spring Washer M10	2
13	FW10	Heavy Flat Washer M10	2
14	25053	Bolster Plate	4

## Suggested Tools for Assembly

- Ratchet and M10 socket
- At least a second Person
- Saw benches or workshop bench both need to be greater than at least 860mm (33 7/8").
- 5/8" or 16mm Ring/ Open End Spanner
- 3/4" or 19mm Ring/Open End Spanner
- 8" Adjustable Spanner

## ASSEMBLY INSTRUCTIONS

1. Remove the 2 cast iron frames and the cardboard box containing the legs.
2. Open the cardboard box and identify the parts against the parts lists provided (above)

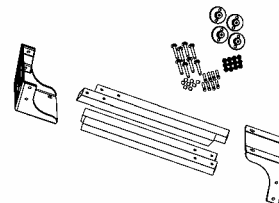

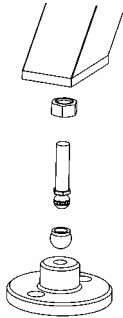
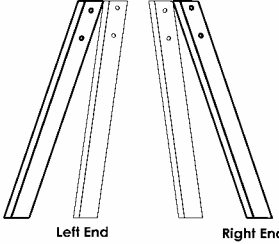
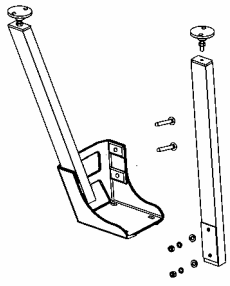
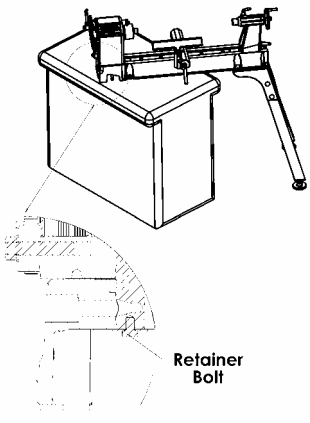
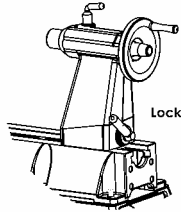
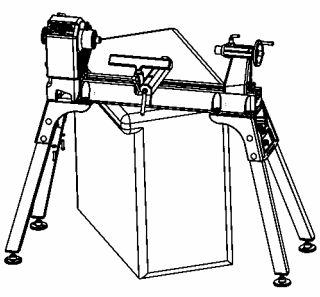
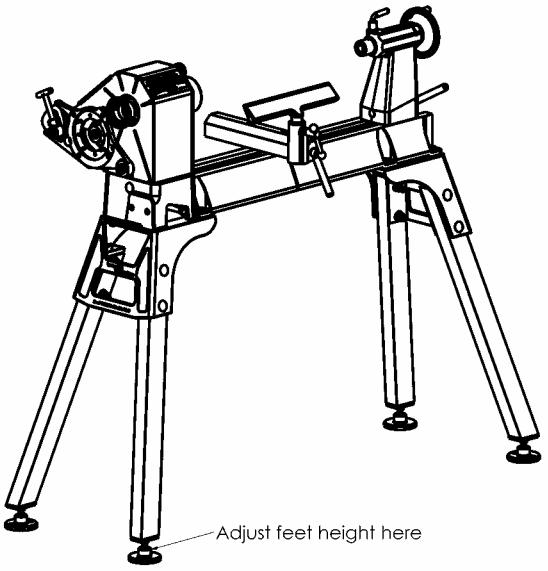
<p>3. Attach each of the feet by inserting the rubber bushing in the socket of the foot and then pressing the ball at the end of each leg piece into the bushing. The rubber will form around the ball firmly holding it into the socket. (Pre-Assembled)</p>		
<p>4. Of the four legs, identify the two different angles. With the cast iron foot flat on the floor, the leg will angle either to the left or right. Angled to the right will go on the left end of the stand. Angled to the left will go on the right end of the lathe.</p>		
	<p>5. With the cast iron frame on the floor add the appropriate legs into the corners and insert the bolster plate, coach bolts, washer and nut</p> <p>6. Repeat for other cast iron frame.</p> <p>7. You will now have a leg set for each end of the lathe.</p>	
		<p>8. Now this is where you need a second person and a table, saw horses or workshop bench of suitable height. (If the table is not high enough then you may need to put blocks underneath.) With the help of a second person, move the lathe from the box and up to the bench or onto the saw horses. It may be easier to cut the box away in order to prevent any dangerous loading on your back.</p> <ul style="list-style-type: none"> <li>• Information 1 <ul style="list-style-type: none"> <li>i. There's a retaining bolt holding the swivel pin of the headstock down on the mainbed. Therefore the lathe can be safely lifted via the headstock without the need of the headstock lockpin.</li> </ul> </li> <li>• Important 2 <ul style="list-style-type: none"> <li>ii. Check the tailstock is securely fastened by tightening the lock arm.</li> </ul> </li> <li>• Once the following checks have been made the headstock and the tailstock can be used to assist in the lifting of the lathe.</li> </ul> <p>9. Move the lathe on the bench so that the tailstock end is overhanging and accessible. Attach the legs sloping to the right on this end. Drop the M10 x 90 hex bolts through the holes and then fasten underneath with the washer and nut.</p>
<p>10. Next do the headstock end. Note that the left most fastenings are inserted upward into two blind holes into the lathe bed</p> 		
<p>11. Level the lathe - The height could be adjusted by adjusting the nut on the feet.</p> <p>12. For further lathe assembly instruction see main manual pg. 9-16</p>		

TEKNATOOL INTERNATIONAL  
65 THE CONCOURSE HENDERSON. AUCKLAND NEW ZEALAND

PHONE: 64-9-837-6900  
FAX: 64 - 9 - 6901  
EMAIL: [sales@teknatool.com](mailto:sales@teknatool.com)  
WEBSITE: [www.teknatool.com](http://www.teknatool.com)