



D.I.Y./Self Help Sheet

REMOVING & REPLACING JAW SLIDES ON YOUR SUPERNOVA OR NOVA CHUCK

Date Raised: 24.8.99

Safe practises should always be employed to ensure the Health and Safety of yourself, employees and customers (if applicable) Refer to product manuals, exploded drawings and our website if further assistance is required, or contact us on service@teknatool.com

Date Amended:

Note: This procedure is identical for the Nova Scroll Chuck and the SuperNova Chuck. Refer to the Information in the chuck manuals - these can be downloaded from the website if you require a new copy on www.teknatool.com If you need more assistance, email us on service@teknatool.com

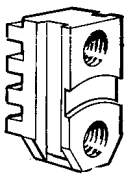

Picture of one of the 4 Jaw Slides in every Nova & SuperNova chuck

Reason the slides may need replacing or re-insertion:

- Maintenance
- Jaw slides have closed in the centre and the No. 1 slide stays in the centre when the jaws are expanded again.
- Jaw slides do not meet when wound to the centre.
- Problem with holes not being tapped out correctly
- Screw broken in jaw slides
- Jaw Slides need to be re-inserted.

Parts required:

- Replacement set of Jaw Slides (if needed) Teknatool Code: 7000

Tools required:

- Small Screwdriver

Procedure:

- Remove lock stop screw from chuck (see illustrations on page over)
- Remove jaw slides from chuck body by unwinding the chuck until the Jaw Slides disengage completely.
- Remove each jaw slide from the Slideways.
- Clean the Slideway and the Jaw Slides.
- Re-insert jaw slides. The Jaw slides are numbered 1 - 4 (numbering is on the end of the slide). The jaws need to be re-set in sequence. Rotate chuck until the lead of the scroll ring (like a thin wedge) appears in the opening of the slide way. It is important to rotate the leading edge of the scroll back slightly to clear the slideway before slide can be inserted. Failure to rotate the scroll back could result in damage to scroll.
 - Insert the No. 1 slide in the slideway. The number should face the outside body of the chuck.
 - Rotate the scroll in a clockwise direction (chuck facing you) until the lead of the scroll appears at the next slideway. Now engage No. 2 jaw slide in the same manner as No 1. Proceed in the same way in a clock-wise sequence with No 3. And No. 4 slides.
 - Wind the Jaw slides into the centre and back to ensure the slides are correctly positioned. Check the slides meet in the middle when they are fully wound into the centre.

- Replace the lock stop screw.

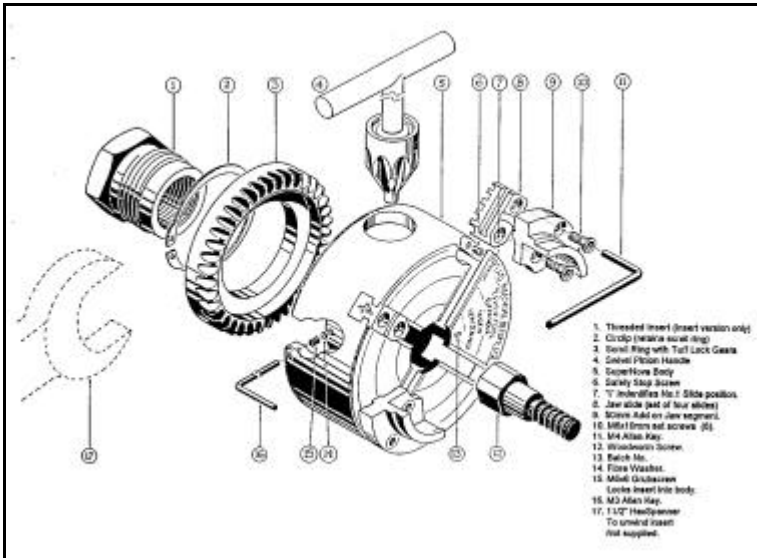

Exploded View of SuperNova Chuck

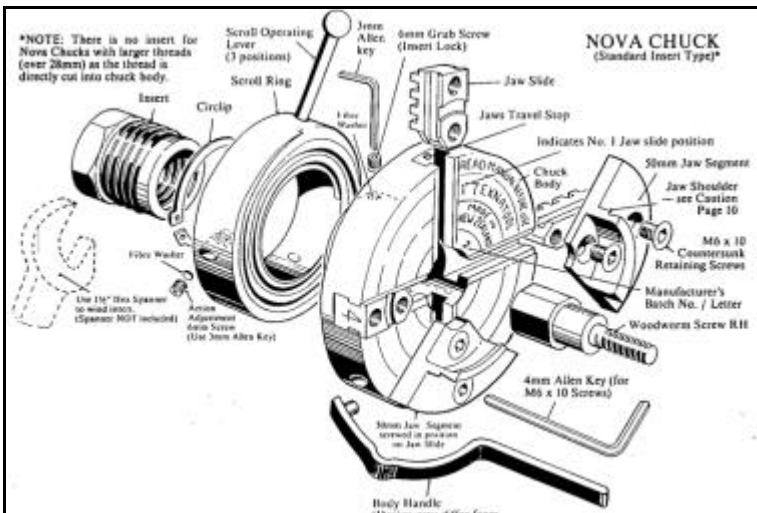

Exploded View of Nova Chuck